

# Technical and Economic Assessment of Off-grid, Mini-grid and Grid Electrification Technologies

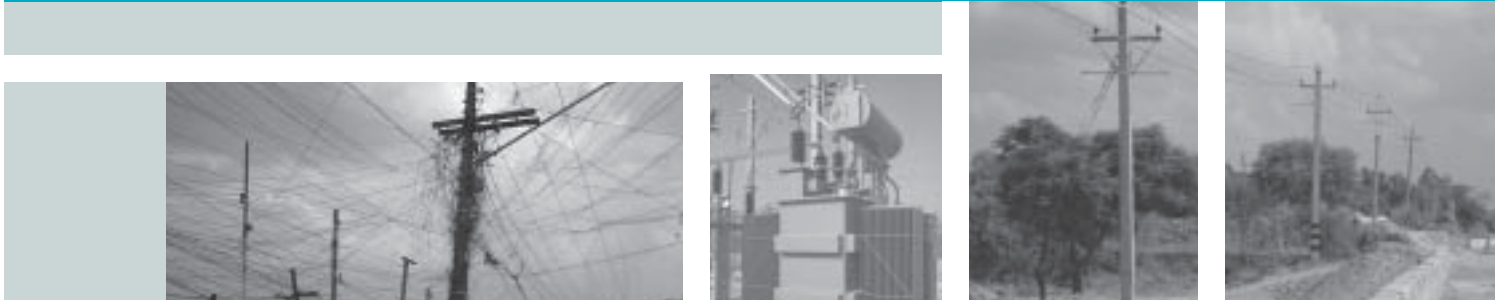

Energy Sector Management Assistance Program

## **Energy Sector Management Assistance Program**

### **Purpose**

The Energy Sector Management Assistance Program (ESMAP) is a global technical assistance partnership administered by the World Bank since 1983 and sponsored by bilateral donors. ESMAP's mission is to promote the role of energy in poverty reduction and economic growth in an environmentally responsible manner. Its work applies to low-income, emerging, and transition economies and contributes to the achievement of internationally agreed development goals through knowledge products such as free technical assistance; specific studies; advisory services; pilot projects; knowledge generation and dissemination; training, workshops, and seminars; conferences and round-tables; and publications.

The Program focuses on four key thematic areas: energy security, renewable energy, energy poverty, and market efficiency and governance.

### **Governance and Operations**

ESMAP is governed by a Consultative Group (CG) composed of representatives of the World Bank, other donors, and development experts from regions that benefit from ESMAP assistance. The ESMAP CG is chaired by a World Bank Vice-President and advised by a Technical Advisory Group of independent energy experts that reviews the Program's strategic agenda, work plan, and achievements. ESMAP relies on a cadre of engineers, energy planners, and economists from the World Bank, and from the energy and development community at large, to conduct its activities.

### **Funding**

ESMAP is a knowledge partnership supported by the World Bank and official donors from Belgium, Canada, Denmark, Finland, France, Germany, Iceland, the Netherlands, Norway, Sweden, Switzerland, United Kingdom, United Nations Foundation, and the United States Department of State. It has also enjoyed the support of private donors as well as in-kind support from a number of partners in the energy and development community.

### **Further Information**

Please visit [www.esmap.org](http://www.esmap.org) or contact ESMAP via email ([esmap@worldbank.org](mailto:esmap@worldbank.org)) or mail at:

ESMAP  
c/o Energy, Transport and Water Department  
The World Bank Group  
1818 H Street, NW  
Washington, DC 20433 USA  
Tel.: 202.458.2321  
Fax: 202.522.3018

ESMAP Technical Paper 121/07

# Technical and Economic Assessment of Off-grid, Mini-grid and Grid Electrification Technologies

Energy and Mining Sector Board  
The World Bank Group

Copyright © 2007  
The International Bank for Reconstruction  
and Development/THE WORLD BANK  
1818 H Street, NW  
Washington, DC 20433 USA

All rights reserved  
Produced in India  
First printing December 2007

ESMAP Reports are published to communicate the results of ESMAP's work to the development community with the least possible delay. The typescript of the paper therefore has not been prepared in accordance with the procedures appropriate to formal documents. Some sources cited in this paper may be informal documents that are not readily available.

The findings, interpretations, and conclusions expressed in this paper are entirely those of the author and should not be attributed in any manner to the World Bank or its affiliated organizations, or to members of its Board of Executive Directors or the countries they represent. The World Bank does not guarantee the accuracy of the data included in this publication and accepts no responsibility whatsoever for any consequence of their use. The boundaries, colors, denominations, other information shown on any map in this volume do not imply on the part of the World Bank Group any judgment on the legal status of any territory or the endorsement or acceptance of such boundaries.

The material in this publication is copyrighted. Requests for permission to reproduce portions of it should be sent to the ESMAP Manager at the address shown in the copyright notice above. ESMAP encourages dissemination of its work and will normally give permission promptly and, when the reproduction is for noncommercial purposes, without asking a fee.

(Papers in the ESMAP Technical Series are discussion documents, not final project reports. They are subject to the same copyright as other ESMAP publications.)

# Contents

Acronyms and Abbreviations	ix
Units of Measure	xii
Chemical Symbols	xiii
Foreword	xv
Acknowledgments	xvii
Executive Summary	xix
1. Introduction	1
Purpose and Scope	2
Methodology	2
Costing Formulations and Projections	3
Uncertainty Analysis	4
Capacity Factor	6
Deployment Venue	6
Fuel Price Forecasts	6
Regional Adjustments	6
Study Limitations	7
2. Power Generation Technology Assessment	9
Renewable Technologies	9
Solar Photovoltaic Power Systems	9
Wind Power Systems	11
SPV-wind Hybrid Power Systems	13
Solar-thermal Electric Power Systems	14
Geothermal Electric Power Systems	15
Biomass Gasifier Power Systems	17
Biomass-steam Electric Power Systems	19
Municipal Waste-to-power via Anaerobic Digestion System	20
Biogas Power Systems	22

Micro- and Pico-hydroelectric Power Systems	23
Mini-hydroelectric Power Systems	25
Large Hydroelectric and Pumped Storage Power Systems	26
Conventional Power Generation Systems	28
Diesel/Gasoline Engine-generator Power Systems	28
Combustion Turbine Power Systems	29
Coal-steam Electric Power Systems	31
Oil-fired Steam-electric Power Systems	32
Emerging Power Generation Technologies	33
Coal IGCC Power Systems	34
Coal-fired AFBC Power Systems	35
Microturbine Power Systems	35
Fuel Cell Power Systems	37
3. Technical and Economic Assessment of Power Delivery	39
Transmission and Distribution Facilities	40
Operations and Maintenance Requirements	41
Power Delivery Losses	41
Economic Assessment of Power Delivery	42
Distribution Costs	42
Transmission Costs	45
Grid Integration Issues	47
4. Results and Discussion	49
Power Generation Technology Configurations	50
Results: Power Generation Capital Costs	50
Results: Levelized Power Generating Costs	54
Discussion: Power Delivery Costs	57
Discussion: Sensitivity of Projected Generation Costs to Technology	
Change and Fuel Costs	57
Conclusion	58
5. References	61
Annexes	CD
Annex 1: Detailed Technology Descriptions and Cost Assumptions	CD
Annex 2: Wind Electric Power Systems	CD
Annex 3: SPV-wind Hybrid Systems	CD
Annex 4: Solar-thermal Electric Power Systems	CD
Annex 5: Geothermal Power Systems	CD
Annex 6: Biomass Gasifier Power Systems	CD
Annex 7: Biomass-steam Power Systems	CD
Annex 8: Municipal Waste-to-power System Using Anaerobic Digestion	CD

Annex 9: Biogas Power Systems	CD
Annex 10: Micro- and Pico-hydroelectric Power Systems	CD
Annex 11: Mini-hydroelectric Power Systems	CD
Annex 12: Large-hydroelectric Power and Pumped Storage Systems	CD
Annex 13: Diesel/Gasoline Engine-generator Power Systems	CD
Annex 14: Combustion Turbine Power Systems	CD
Annex 15: Coal-steam Electric Power Systems	CD
Annex 16: Coal-IGCC Power Systems	CD
Annex 17: Coal-fired AFBC Power Systems	CD
Annex 18: Oil-fired Steam-electric Power Systems	CD
Annex 19: Microturbine Power Systems	CD
Annex 20: Fuel Cells	CD
Annex 21: Description of Economic Assessment Methodology	CD
Annex 22: Power Generation Technology Capital Cost Projections	CD
Annex 23: High/Low Charts for Power Generation Capital and Generating Costs	CD
Annex 24: Data Tables for Generation Capital Cost and Generating Costs	CD
Annex 25: Environmental Externalities	CD
Annex References	CD

# Tables

Table 1:	World Bank FY 2003-05 Investment in Electricity Access	xx
Table 2:	Generation Technology Options and Configurations	xxii
Table 1.1:	Capital Costs Projections by Generation Technology	4
Table 1.2:	Uncertainty Variables for Analysis	5
Table 1.3:	Fossil Fuel Price Projections	7
Table 2.1:	Solar PV Configurations Assessed	10
Table 2.2:	Targets for SPV Future Costs	11
Table 2.3:	Wind Turbine Performance Assumptions	12
Table 2.4:	Solar-thermal Electric Power System Design Parameters	15
Table 2.5:	Design Assumptions for Geothermal Power Plants	16
Table 2.6:	Geothermal Power Capital Costs by Project Development Phase	17
Table 2.7:	Biomass Gasifier Design Assumptions	18
Table 2.8:	Biomass-steam Electric Power Plant Design Assumptions	20
Table 2.9:	Municipal Waste-to-power System Characteristics	21
Table 2.10:	Biogas Power System Design Assumptions	23
Table 2.11:	Micro- and Pico-hydroelectric Power Plant Design Assumptions	25
Table 2.12:	Mini-hydroelectric Power Plant Design Assumptions	25
Table 2.13:	Large Hydroelectric Power Design Assumptions	27
Table 2.14:	Gasoline and Diesel Engine-generator Design Assumptions	29
Table 2.15:	Emission Characteristics of Diesel Generators	29
Table 2.16:	CT and CCGT Design Assumptions	30
Table 2.17:	Coal-fired Steam-electric Power Plant Design Assumptions	31
Table 2.18:	Oil-fired Steam-electric Power Plant Design Assumptions	33



Table 2.19:	Emissions from Oil-fired Steam-electric Power Plants	33
Table 2.20:	Coal-fired IGCC Power Plant Design Assumptions	34
Table 2.21:	Emission Results for a Coal-fired AFBC Power Plant	35
Table 2.22:	Gas-fired Microturbine Design Assumptions	37
Table 2.23:	Fuel Cell Power System Design Assumptions	38
Table 3.1:	Power Delivery Requirements According to Generation Configuration	39
Table 3.2:	Transmission Voltages in Developing Countries	40
Table 3.3:	Power Delivery Loss Rates in Selected Countries	41
Table 3.4:	Power Delivery Costs Associated with Mini-grid Configurations	44
Table 3.5:	Assigning Transmission Line Costs According to Power Station Output	46
Table 3.6:	Power Delivery Costs Associated with Transmission Facilities	46
Table 3.7:	Costs of Accommodating Wind Power Intermittency	48
Table 4.1:	2005 Renewable Power Technology Capital Costs	51
Table 4.2:	2005 Conventional and Emerging Power Technology Capital Costs	52
Table 4.3:	Power Generation Technology Capital Costs Now and in Future (2005, 2010, 2015)	52
Table 4.4:	2005 Renewable Power Technology Generating Costs	55
Table 4.5:	2005 Conventional/Emerging Power Technology Generating Costs	56
Table 4.6:	Levelized Generating Cost with Uncertainty Analysis	59

# Figures

Figure 1:	Off-grid Forecast Generating Cost	xxiii
Figure 2:	Mini-grid Forecast Generating Costs	xxiv
Figure 3:	Grid-connected Forecast Generating Costs	xxvi
Figure 1.1:	JSIM Labor Factor by Region	8
Figure 2.1:	Stand-alone Solar Photovoltaic System	10
Figure 2.2:	Projected Wind Power Costs, 2000-25	12
Figure 2.3:	SPV-wind DC- and AC-coupled Arrangement	13
Figure 2.4:	Solar-thermal Electric Power Plant	14
Figure 2.5:	Binary Hydrothermal Power Plant Schematic	17
Figure 2.6:	Biomass Gasification Process Schematic	18
Figure 2.7:	Biomass-fired Steam Electric Power Plant	19
Figure 2.8:	Municipal Waste-to-power via Anaerobic Digestion	21
Figure 2.9:	Fixed Dome Biogas Plant	22
Figure 2.10:	Micro-hydroelectric Power Scheme	24
Figure 2.11:	Conduit-type Intake Arrangement for Large Hydroelectric Power Plant	26
Figure 2.12:	Pumped Storage Hydroelectric Power Arrangement	27
Figure 2.13:	Diesel-electric Power Generation Scheme	28
Figure 2.14:	Combined Cycle Gas Turbine Schematic	30
Figure 2.15:	Coal-fired Steam-electric Power Plant	31
Figure 2.16:	Oil-fired Steam-electric Power Plant	32
Figure 2.17:	Coal-fired IGCC Power Plant Arrangements	34
Figure 2.18:	Coal-fired AFBC Boiler Schematic	36
Figure 2.19:	Gas-fired Microturbine Schematic	36
Figure 2.20:	Operation of a Fuel Cell	38
Figure 3.1:	Calculation Model for Distribution Costs	43
Figure 3.2:	Calculation Model for Transmission Costs	45

# Acronyms and Abbreviations

ACSR	aluminum conductor steel reinforced
AD	anaerobic digestion
AFBC	atmospheric fluidized bed combustion
AFUDC	allowance for funds used during construction
AHEC	Alternate Hydro Energy Centre
BoS	balance of system
CCGT	combined cycle gas turbine
CFB	circulating fluidized bed
CHP	combined heat and power
CT	combustion turbine
DD	direct drive
DFIG	doubly-fed induction generator
DRR	dose-response relationship
DSS	direct solar steam
EGS	engineered geothermal systems
EnTEC	Energy Technologies Enterprises Corporation
EPC	engineering, procurement and construction
EPRI	Electric Power Research Institute
ESHA	European Small Hydro Association
ESP	electrostatic precipitator
EWEA	European Wind Energy Association
FGD	flue gas desulfurization
FY	fiscal year (July 1-June 30)
GDP	gross domestic product
GEA	Global Energy Associates, Inc.
GEF	Global Environment Facility

GHGs	Greenhouse gases
HRSR	heat recovery steam generator
HRT	hydraulic retention time
IAP	infrastructure action plan
IBRD	International Bank for Reconstruction and Development
IC	internal combustion
ICB	international competitive bidding
IDA	International Development Association
IEA	International Energy Agency
IGCC	integrated gasification combined cycle
IN-SHP	International Network for Small Hydro Power
JICA	Japan International Cooperation Agency
LAC	Latin America and Caribbean
LHV	lower heating value
LNG	liquefied natural gas
LPG	liquefied petroleum gas
MCFC	molten carbonate fuel cell
MENA	Middle East North Africa
MDGs	Millennium Development Goals
MSW	municipal solid waste
NERC	North American Reliability Council
NREL	National Renewable Energy Laboratory
O&M	operation and maintenance
PAFC	phosphoric acid fuel cell
PC	pulverized coal
PEFC	polymer electrolyte fuel cell
PERI	Princeton Energy Resources International
PM	particulate matter
PV	photovoltaic
RE	renewable energy
RETs	renewable energy technologies
RoR	run-of-the-river
RPM	resolutions per minute
SC	SuperCritical
SCR	selective catalytic reduction

SHP	small hydro power
SNCR	selective noncatalytic reduction
SOFC	solid oxide fuel cell
SPV	solar photovoltaic
SVC	Static VAR Compensato
TAG	Technical Assessment Guide
TCR	total capital requirement
T&D	transmission and distribution
TPC	total plant cost
TPI	total plant investment
USC	UltraSuperCritical
USDoE	The United States Department of Energy

# Units of Measure

AC	alternating current
C	celsius
DC	direct current
F	fahrenheit
Kg	kilogram (s)
kV	kilo volt
kW	kilo watt (s)
kWh	kilo watt (s) per hour
m	meter (s)
MW	mega watt (s)
PPM	parts per million
V	volt
W	watt

# Chemical Symbols

C	carbon
CaSO <sub>4</sub>	calcium sulfate
CO	carbon monoxide
CO <sub>2</sub>	carbon dioxide
CH <sub>4</sub>	methane
H	hydrogen
HCl	hydrogen chloride
Hg	mercury
H <sub>2</sub> S	hydrogen sulfide
K	potassium
N	nitrogen
Na	sodium
NO <sub>x</sub>	nitrogen oxides
NH <sub>3</sub>	ammonia
O	oxygen
SiO <sub>2</sub>	silica
SO <sub>2</sub>	sulfur dioxide
SO <sub>x</sub>	sulfur oxides





# Foreword

Helping power sector planners in developing economies to factor in emerging electrification technologies and configurations is essential to realizing national electrification agendas at minimum cost. New generation technologies, especially based on renewable energy (RE), and new electrification approaches, especially based on stand-alone mini-grids or off-grid configurations, are part of the growing complexity which electrification policy makers and power system planners must be able to factor into their investment programs.

This report is part of the Energy and Water Department's commitment to providing new techniques and knowledge which complement the direct investment and other assistance to electrification as provided by the International Bank for Reconstruction and Development (IBRD) and the International Development Association (IDA).

Our hope is that it will stimulate discussion among practitioners both within the World Bank and, in the larger community of power system planners. We note that the findings and results are imperfect at best and that much additional analytic work is required to keep up with the growing variety of power generation technologies and increasing complexity of formulating least-cost power sector development and electrification plans.

Jamal Saghir  
Director  
Energy and Water Department  
Chair, Energy and Mining Sector Board  
The World Bank



# Acknowledgments

The electrification assessment study was undertaken by a team comprising Toyo Engineering Corporation, Chubu Electric Power Co. Inc., Princeton Energy Resources International (PERI), Energy Technologies Enterprises Corp (EnTEC), and Global Energy Associates, Inc (GEA). The report itself was prepared by several authors including Mr. K. R. Umesh (Toyo Engineering Company), Mr. Takashi Nakase, Mr. Keiichi Yoneyama and Toshiomi Sahara (Chubu Electric Power Company), Mr. Stratos Tavoulareas (EnTEC), Mr. Mahesh Vipradas (TERI) and Mr. Grayson Heffner (GEA). Mr. Chuck McGowan of Electric Power Research Institute (EPRI), and Mr. Joe Cohen and Mr. John Rezaiyan of PERI provided many helpful comments on the technical and economic assumptions underlying our assessment. The study and report preparation were managed by Mr. Masaki Takahashi of the Energy and Water Department with the assistance of Mr. Anil Cabraal.

The study team members and the World Bank staff would like to dedicate this report to the memory of Dr. Tom Schweizer of Princeton Energy Resources International (PERI) who passed away last year as the assessment phase of the study was nearing completion. Tom was a dedicated and invaluable colleague always ready to cooperate and offer his services and advice.

Please address any questions or comments about this report to Mr. Masaki Takahashi ([mtakahashi@worldbank.org](mailto:mtakahashi@worldbank.org)).



# Executive Summary

## Background

Today's levels of energy services fail to meet the needs of the poor. Worldwide, two billion people rely on traditional biomass fuels for cooking and 1.6 billion people do not have access to electricity. Unless investments in providing modern energy services are expanded significantly, this number is expected to actually increase over the next 30 years (International Energy Agency [IEA], 2002). This lack of access to quality energy services, especially electricity, is a situation which entrenches poverty, constrains the delivery of social services, limits opportunities for women and girls, and erodes environmental sustainability at the local, national and global levels. Ignoring the situation will undermine economic growth and exacerbate the health and environmental problems now experienced in many parts of the world.

Developing and transition countries face huge investments in providing the energy access needed to achieve the Millennium Development Goals (MDGs). The IEA estimates the electricity sector investment requirements in developing countries to reach the MDG goal of halving poverty to be US\$16 billion annually over the next 10 years (IEA, 2004). Mobilizing such investment and, in particular, undertaking the challenges of rural electrification will require strong political determination, a willingness to prioritize electrification within the overall development agenda and considerable skill in the selection and implementation of technical and economic strategies for electrification.

Experience throughout the world has shown that there is no single or unique way of achieving electrification, either from a financing and implementation viewpoint or from an electrification technology viewpoint. Furthermore, the range of electrification technologies is constantly expanding, and the factors determining the ultimate affordability, availability and sustainability of a particular electrification scheme are becoming increasingly complex. Developments in generation technology and electrification business models have resulted

in increasing diversity in how electricity is generated and delivered to end users, including grid-connected mini-grid and off-grid arrangements.

This growing diversity of electrification arrangements is reflected in the World Bank's patterns of lending for electrification. A recent review of the World Bank energy projects approved during fiscal year (FY) 2003 through 2005 identified almost US\$500 million in direct physical investments in electricity access (The World Bank, 2006). The portfolio review identified four categories of electricity access investment – Grid-based Peri-urban Electrification; Grid-based Rural Electrification; Off-grid Rural Electrification; and Electrification Funds (Table 1). The review confirmed that grid-connected electrification remained the dominant electrification arrangement, but identified considerable regional variations, with off-grid investment important in Africa and predominant in Latin America and Caribbean (LAC). Off-grid electrification comprised almost 10 percent of the total assistance to electrification provided by the World Bank over the past three fiscal years. This proportion is expected to grow along with progress toward universal access, as remaining populations will be more difficult to economically electrify using conventional grid extension arrangements.

**Table 1: World Bank FY 2003-05 Investment in Electricity Access (US\$ millions)**

<i>Region</i>	<i>Grid Peri-urban</i>	<i>Grid Rural Electrification</i>	<i>Off-grid Electrification</i>	<i>Rural Energy Fund</i>	<i>Total</i>
Africa	US\$76.6	US\$35.2	US\$30.2	US\$31.2	US\$173.2
E Asia Pacific	US\$0.0	US\$235.0	US\$3.7	US\$8.3	US\$247.0
L America Car	US\$0.0	US\$3.0	US\$7.0	US\$0.0	US\$10.0
South Asia	US\$26.0	US\$0.0	US\$5.5	US\$24.6	US\$56.1
N Africa Med	US\$0.0	US\$0.0	US\$0.0	US\$0.0	US\$0.0
E Europe CA	US\$0.0	US\$0.0	US\$0.0	US\$0.0	US\$0.0
<b>Total</b>	<b>US\$102.6</b>	<b>US\$273.2</b>	<b>US\$46.4</b>	<b>US\$64.1</b>	<b>US\$486.3</b>

Source: *The World Bank, 2006.*

## Purpose

The purpose of this report is to convey the results of an assessment of the current and future economic readiness of electric power generation alternatives for developing countries. The objective of the technical and economic assessment was to systematically characterize the commercial and economic prospects of renewable and fossil fuel-fired electricity generation technologies now, and in the near future.

Our hope is that this assessment will be useful to electrification planners concerned with anticipating technological change in the power sector over the next 10 years, especially as regards emerging RE technology, new prime mover technology and hybrid configurations which can potentially deliver improved performance and better economics for a given electrification situation. We also wanted to provide these planners and policy makers with systematic comparisons of the economics of various technologies when configured in grid-connected, mini-grid and off-grid applications.

## Scope

We examined power generation technologies across a size range of 50 watt (W) to 500 mega watt (s) (MW) organized into three distinct electricity delivery configurations: off-grid, mini-grid and grid (Table 2). Generation technologies examined included renewable energy technologies (RETs), (photovoltaic [PV], wind, geothermal, hydro, biomass-electric, biogas-electric); conventional generation technologies (gasoline or diesel generator; oil/gas steam-electric, combustion turbines (CTs) and combined cycle; coal-fired steam-electric); and emerging technologies (integrated gasification combined cycle [IGCC], Atmospheric Fluidized Bed Combustion [AFBC], fuel cells and microturbines). The economic assessment was performed for three different time periods (2005, 2010 and 2015) in order to incorporate projected cost reductions from scaling-up of emerging technologies. A levelized analysis of capital and generation costs was conducted in economic, rather than financial terms, to allow generic applications of results to any developing country. Capital and generation cost projections incorporated uncertainty analysis, allowing the results to reflect sensitivity to key input assumptions. The study results make it possible to compare the levelized economic costs of electricity technologies over a broad range of deployment modes and demand levels, both at present, and in the future.

**Table 2: Generation Technology Options and Configurations**

Generating-types	Life Span (Year)	Off-grid		Mini-grid		Grid-connected			
		Capacity	CF (%)	Capacity	CF (%)	Base Load		Peak	
						Capacity	CF (%)	Capacity	CF (%)
Solar-PV	20 25	50 W 300 W	20	25 kW	20	5 MW	20		
Wind	20	300 W	25	100 kW	30	10 MW 100 MW	30		
PV-wind-hybrids	20	300 W	25	100 kW	30				
Solar Thermal With Storage	30					30 MW	50		
Solar Thermal Without Storage	30					30 MW	20		
Geothermal Binary	20			200 kW	70				
Geothermal Binary	30					20 MW	90		
Geothermal Flash	30					50 MW	90		
Biomass Gasifier	20			100 kW	80	20 MW	80		
Biomass Steam	20					50 MW	80		
MSW/Landfill Gas	20					5 MW	80		
Biogas	20			60 kW	80				
Pico/Microhydro	5 15 30	300 W 1 kW	30 30						
				100 kW	30				
Mini Hydro	30					5 MW	45		
Large Hydro	40					100 MW	50		
Pumped Storage Hydro	40							150 MW	10
Diesel/Gasoline Generator	10 20	300 W, 1 kW	30						
				100 kW	80	5 MW	80	5 MW	10
Microturbines	20			150 kW	80				
Fuel Cells	20			200 kW	80	5 MW	80		
Oil/Gas Combined Turbines	25							150 MW	10
Oil/Gas Combined Cycle	25					300 MW	80		
Coal Steam Subcritical	30					300 MW	80		
Sub, SC, USC	30					500 MW	80		
Coal IGCC	30 30					300 MW 500 MW	80 80		
Coal AFB	30 30					300 MW 500 MW	80 80		
Oil Steam	30					300 MW	80		



## Findings

The assessment process revealed emerging trends in terms of the relative economics of renewable and conventional generation technologies according to size and configuration. In interpreting and applying these findings, it should be kept in mind that the assessment effort is a desk study bound by time (technology and prices are not static) and method (it consolidates secondary source information rather than generating new content).

- **Renewable energy is more economical than conventional generation for off-grid (less than 5 kW) applications.** Several RE technologies – wind, mini-hydro and biomass-electric – can deliver the lowest levelized generation costs for off-grid electrification (Figure 1), assuming availability of the renewable resource. Pico-hydro, in

**Figure 1: Off-grid Forecast Generating Cost**

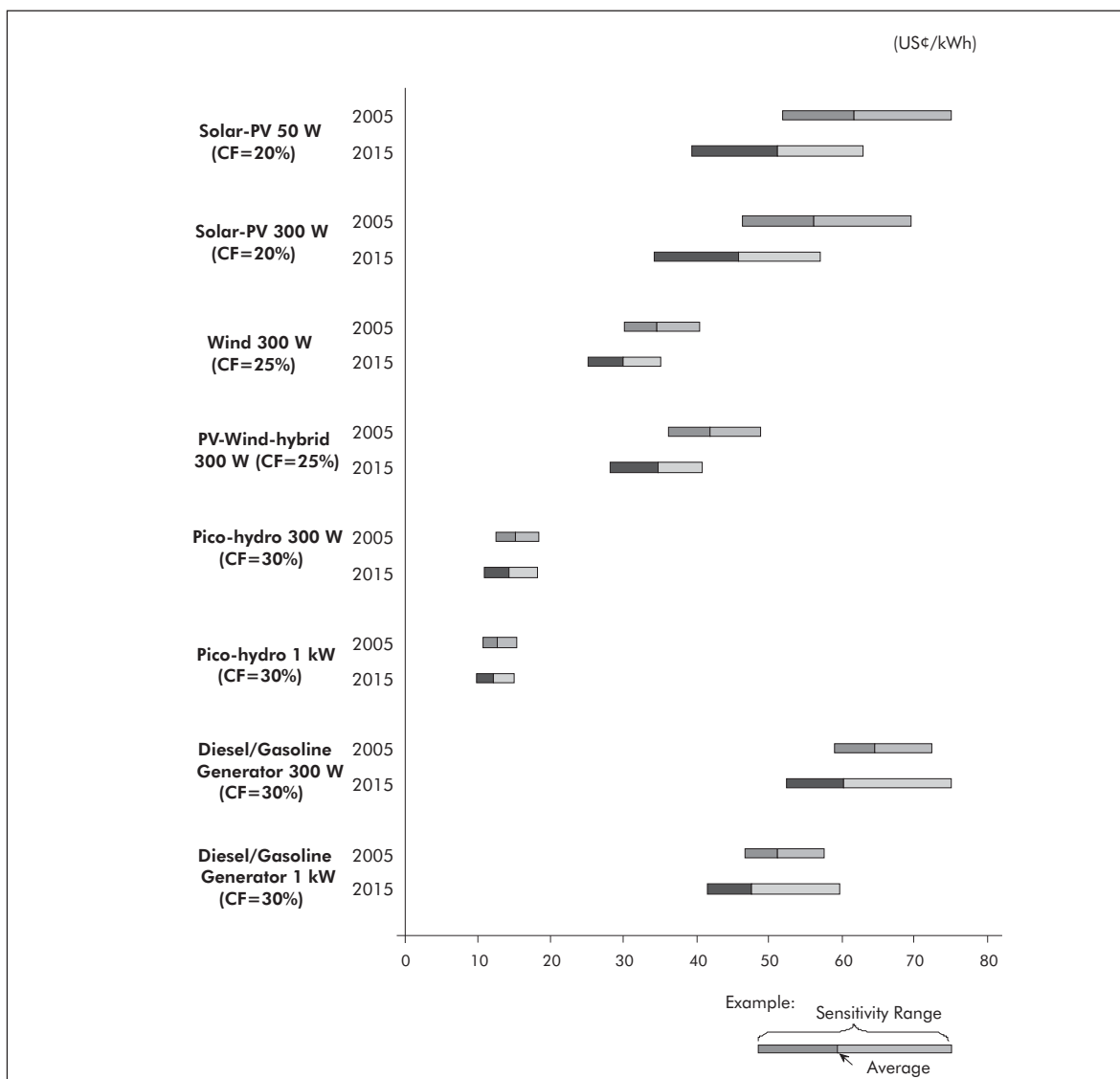

particular, can deliver electricity for US¢10-20/kilo watt (s) per hour (kWh), less than one-quarter of the US¢40-60/kWh for comparably-sized gasoline and diesel engine generators. Even relatively expensive RET (solar PV) is comparable in levelized electricity costs to the small fuel-using engine generators under 1 kilo watt (s) (kW) in size.

- **Several renewable energy technologies are potentially the least-cost mini-grid generation technology.** Mini-grid applications are village- and district-level isolated networks with loads between 5 kW and 500 kW. The assessment results suggest several RETs (biomass, geothermal, wind and hydro) may be the most economical generation choice for mini-grids, assuming a sufficient renewable resource is available (Figure 2).

**Figure 2: Mini-grid Forecast Generating Costs**

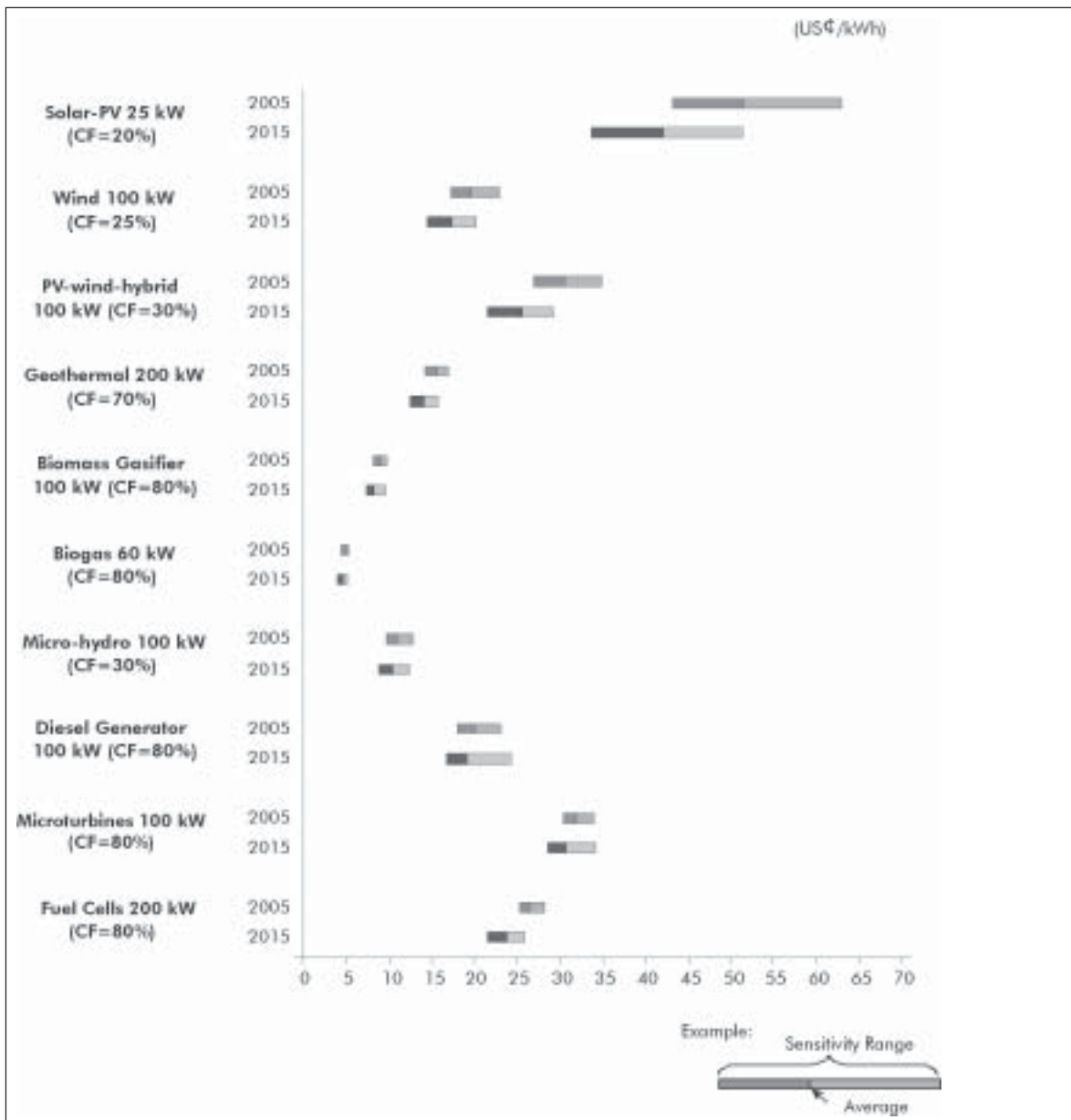

Two biomass technologies – biogas digesters and biomass gasifiers – seem particularly promising, due to their high capacity factors and availability in size ranges matched to mini-grid loads. Since so many RE sources are viable in this size range, mini-grid planners should thoroughly review their options to make the best selection.

- **Conventional power generation technologies (open cycle and combined cycle gas turbines [CCGTs], coal- and oil-fired steam turbines) remain more economical for most large grid-connected applications, even with increases in oil price forecasts (Figure 3).** Site-specific considerations, such as load profile, demand and cost differentials between oil, natural gas and coal prices, determine which configuration is the least expensive. Using SuperCritical or UltraSuperCritical (USC) for very large (over 500 MW) power plants is most cost-effective when fuel prices are high and carbon dioxide (CO<sub>2</sub>) reductions are sought.
- **Two new coal technologies have considerable potential for developing economies.** Two new coal-fired power plant technologies – Integrated Gasification Combined Cycle (IGCC) and AFBC – are attracting considerable attention by planners of large power grids in countries with coal or lignite reserves. AFBC is already commercially available up to 300 MW size, and is used widely worldwide, including China and India. This technology is competitive in situations where low quality inexpensive fuel is available and when sulfur dioxide (SO<sub>2</sub>) emission regulations require a wet scrubber. In the 100 to 300 MW range, the circulating fluidized bed (CFB) option is preferable. The AFBC option may also be applicable to smaller thermal power plants (under 100 MW) using biomass and municipal solid wastes (MSW). IGCC is in the early commercialization stage and could become a viable and competitive option in the future given its excellent environmental performance (Figure 3).

## Considerations for Power System Planners

Power system planners generally operate on an incremental basis, with new capacity additions selected to accommodate the location and pace of load growth on a least-cost basis. The findings provided here suggest that scale is a critical aspect affecting the economics of different generation configurations. When the national or regional grid is developed and includes sufficient transmission capacity, and incremental load growth is fast, large, central-station gas combined cycle and coal-fired power plants would clearly be the least-cost alternatives. However, if the size of the grid is limited, or the incremental load growth is small, it may make economic sense to add several smaller power stations rather than one very large power station. Taking advantage of local resources such as indigenous coal, gas, biomass or geothermal or wind or hydro, and constructing smaller power stations,

**Figure 3: Grid-connected Forecast Generating Costs (US¢/kWh)**

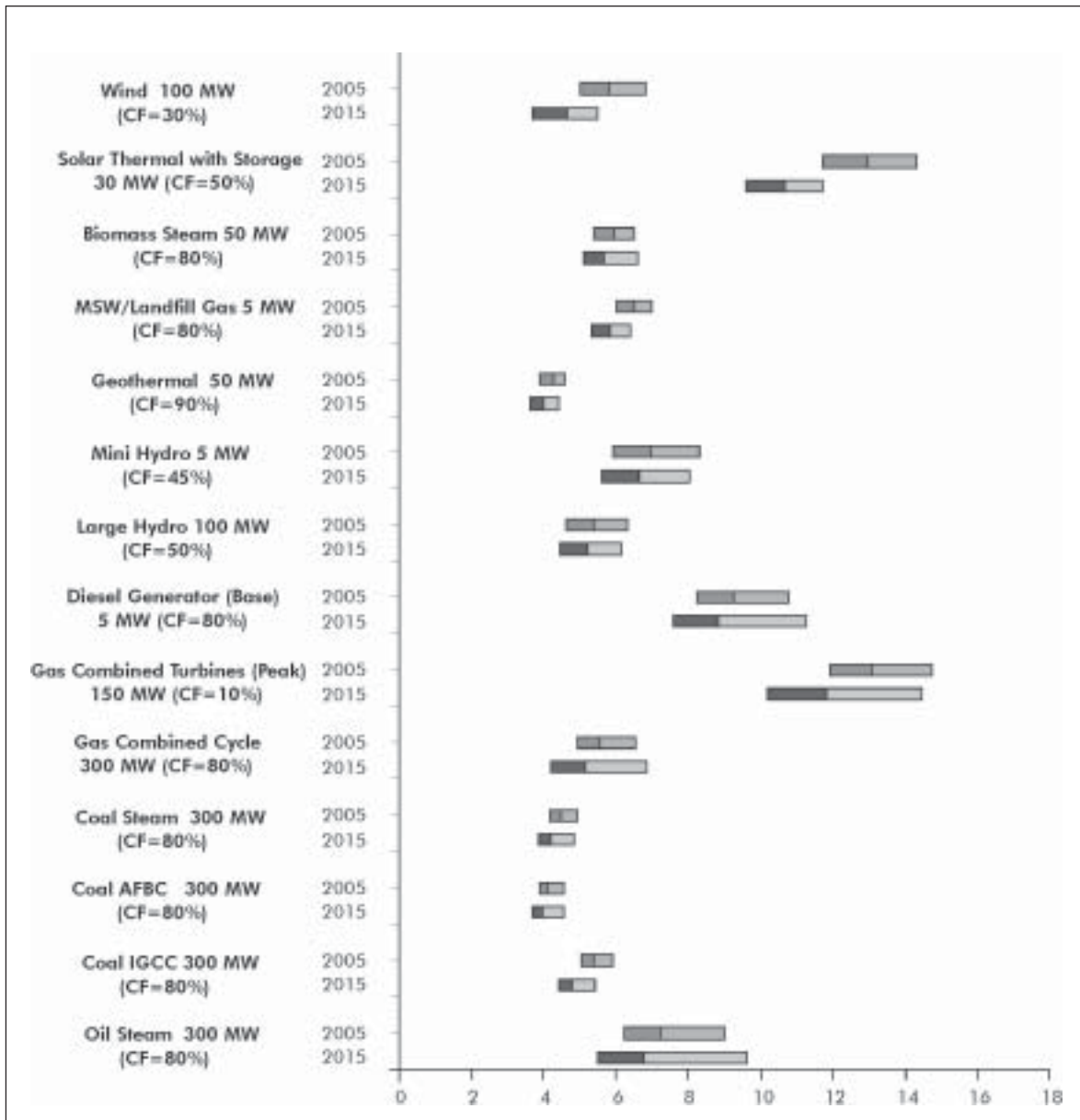

See Annex 4 for results for more grid-connected applications.

may provide energy security and avoid some of the uncertainty associated with international fuel prices as well as the risk associated with financing and constructing very large power plants.

### Recommendations for Future Work

The findings described above suggest that choosing generation technologies and electrification arrangements is becoming a more complicated process. New technologies

are becoming more economical and technologically mature, uncertainty in fuel and other inputs is creating increasing risk regarding future electricity costs, and old assumptions about economies of scale in generation may be breaking down. The assessment methods used here provide a useful comparison among technologies, but need further refinement before becoming the basis of national or regional electrification plans. Accounting for the locational and stochastic variability of renewable resources, as well as balancing costs, land costs, labor and transport costs, all need further investigation, as does the method of accounting for the incremental cost of delivering electricity. The need to accommodate environmental externalities in the economic assessment also needs more attention. Finally, the relative economics of conventional vs. RE is largely driven by forecasts of fuel prices together with certain construction and manufacturing materials prices, such as steel, concrete, glass and silicon. All these commodity prices are increasingly subject to uncertainties and price fluctuations in possibly countervailing directions, which make forecasts of future generation costs extremely uncertain. Additional work, including use of hedging or other financial risk mitigation instruments, is needed to quantify and reflect these future fuel and commodity price uncertainties as part of the electrification planning process.<sup>1</sup>

---

<sup>1</sup> See, for example, "A Level Playing Field for Renewables: Accounting for the Other Externality Benefits." Shimon Awerbach, University of Sussex. Presented to the European Conference for Renewable Energy: Intelligent Policy Options, January 20, 2004.



# 1. Introduction

This power generation technology assessment study is motivated by the World Bank's renewed commitment to both infrastructure development generally, and scaling up access to electricity, in particular. This renewed commitment to the importance of infrastructure within the overall development agenda is described in the 2003 infrastructure action plan (IAP), a comprehensive management tool, which will guide the World Bank Group's infrastructure business for the next few years. The action plan emphasizes more investments, as well as country diagnostic work and encouragement of more private participation, in order to reposition infrastructure as a key contributor to achieving the Millennium Development Goals (MDGs) (The World Bank, 2003).

Embedded within the Infrastructure Action Plan are commitments by the World Bank Group to scale up both investments in modern energy for the urban and rural poor, and its support for renewable energy (RE) development. Between 1994 and 2004, the World Bank (International Bank for Reconstruction and Development [IBRD] and International Development Association [IDA]) commitment in the power sector has totaled US\$17 billion, a level that the IAP proposes to substantially increase. During the same period, IBRD and IDA commitments, together with carbon (C) financing and Global Environment Facility (GEF) cofinancing for RE, specifically, has totaled US\$6 billion (The World Bank, 2005). At the 2004 Bonn International Conference on Renewable Energy, the World Bank Group agreed to increase its RE support by 20 percent each year for the next five years. Increased commitment by the World Bank Group in these two overlapping areas is essential, as the commitments made in Bonn by the developing countries alone is US\$10 billion per year for the next 10 years, while annual power sector investment needs in developing and transition countries are expected to average US\$280 billion per year – twice the level of investment in previous years (International Energy Agency [IEA], 2004).

Carrying out these global commitments, to scaling up access to electricity and investment in RE, requires the most up to date information on technologies and energy economics available. Assessment of the technical, economic and commercial prospects for electricity

generation and delivery technologies is needed in order to make intelligent decisions regarding investments in delivering electricity services at the lowest economic cost, and with maximum social and environmental benefits. An up to date electricity generation and delivery knowledge base in an easily accessible form will help in providing the information needed for countries to incorporate the latest technology developments in their national electrification plans.

Technologies for power generation and delivery continue to emerge and find commercial application. New prime mover technology, emerging renewable technology, new and hybrid configurations combining to deliver improved power plant attributes and better economics of small systems, all combine to create a broad spectrum of choice for power system planning on a national, provincial, local, and even household level. The technical and economic assessment of electrification technologies provided here seeks to characterize and organize this broad spectrum of technology choice for urban and rural energy planners.

## **Purpose and Scope**

The purpose of this report is to provide a technical and economic assessment of commercially available and emerging power generation technologies. The study was designed to cover the widest possible range of electrification applications faced by energy services delivery and power system planners, whether supply is provided through grid networks or stand-alone or mini-grid configurations. The assessment was conducted using a standard approach and is presented in a consistent fashion for each power generation technology configuration. The assessment time frame includes current status and forecast development trends over the period 2005-15, while the economic assessment considers a range of typical operating conditions (peak, off-peak) and grid configurations (off-grid, mini-grid, interconnected grid) for various scales of demand. The technology characterization reflects the current stage of commercialization, including indicative cost reduction trends over 10 years. The study outputs allows for comparison of levelized electricity costs for the full spectrum of electrification technologies over a matrix of deployment modes and demand levels.

## **Methodology**

The methodology comprises a five-step process. First, a technology assessment was undertaken for each candidate generation technology. The assessment covered operating principles, application for electrification purposes and prospects for performance improvement and capital cost reduction. An environmental characterization came next,



which focused on typical environmental impacts from normal operations using typical emission control measures and costs.<sup>2</sup> The assessment assumes use of emission controls in accordance with the World Bank environmental guidelines; these costs are included in the economic assessment. The third step was a capital cost assessment using a standard mathematical model and actual cost data (where available) and reflecting typical deployment.<sup>3</sup> Future capital costs of generation were then developed, based on technology forecasts (for example, learning curves) and incorporating uncertainties in equipment cost, fuel cost and capacity factor. The uncertainty analysis is a parametric analysis of variability in key inputs and generates a band of maximum and minimum costs for each period (2005, 2010 and 2015). Finally, levelized generating costs were calculated using a consistent economic analysis method, but differentiated according to deployment conditions. This last step also included an uncertainty analysis on the inputs to the levelized cost calculation, again generating a band of maximum and minimum costs for the 2005, 2010 and 2015 periods. All cost estimates were developed for a single reference location (India) to minimize any site-specific discrepancies when comparing technologies.

### Costing Formulations and Projections

We selected commonly used formulations of capital costs and generation costs from the engineering economics literature. Capital cost is calculated on a unit basis (per [kilo watt (s) kW]) as the sum of equipment costs (including engineering) plus civil, construction and physical contingency costs. Operating costs are simply the sum of fixed and variable operation and maintenance (O&M) costs plus fuel costs expressed on a per unit output basis. Land cost is not included.

We define generating cost as the sum of capital cost and operating cost, expressed on a levelized unit cost basis (US\$ per [kilo watt (s) per hour] kWh), with levelizing conducted over the economic life of the plant. Levelizing is done using a 10 percent real discount rate that is assumed to be the opportunity cost of capital.<sup>4</sup>

---

<sup>2</sup> Capital and operating cost calculations assume generating equipment complies with the World Bank environmental guideline (Pollution Prevention and Abatement Handbook, July 1998). The Emission Standards are: (i) SO<sub>x</sub> (sulfur oxides) – <500 MW (mega watt (s)) : 0.2 tpd/MW, or ≤2000 mg/Nm<sup>3</sup>; (ii) NO<sub>x</sub> (nitrogen oxides – Coal: 750 mg/Nm<sup>3</sup>; Oil: 460; Gas:320; Gas Turbine:125 for gas; 165 for diesel; 300 for fuel oil; and (iii) PM – 50 mg/Nm<sup>3</sup>.

<sup>3</sup> As described in the Annexes, the cost assessment utilized a cost formulation based on the Electric Power Research Institute's Technical Assessment Guide (TAG).

<sup>4</sup> Detailed formulation of these cost equations is provided in Annex 2.

The analysis was conducted on an economic, rather than a financial basis. An economic analysis assesses the opportunity costs for the project; transfer payments such as taxes, duties, interest payments (including interest during construction) and subsidies are not included. Similarly, physical contingencies are included in the analysis, but price contingencies are not. The analysis is done in real 2004 US\$. The environmental costs/benefits of a particular technology are given in physical quantities without any attempt at monetary valuation, as such valuations must be country- and site-specific.

Some technologies have the potential for significant capital cost reductions due to scaling up and technology improvements. The cost reduction potential varies according to the maturity of the technology and potential for improvements. Based on the literature and industry forecasts, we assumed cost reduction trajectories as shown in Table 1.1.

**Table 1.1: Capital Cost Projections by Generation Technology**

<i>Decrease in Capital Cost (2004 to 2015)</i>	<i>Generating Technology-type</i>
0%-5%	Geothermal, Biomass Steam, Biogas, Pico/Microhydro, Mini Hydro, Large Hydro, Pumped Storage, Diesel/Gasoline Generator, Coal Steam (SubCritical and SuperCritical), Oil Steam
6%-10%	Biomass Gasifier, MSW/Landfill, Gas Combustion, Gas Combined Cycle, Coal Steam USC, Coal AFBC
11%-20%	Solar-PV, Wind, PV-wind-hybrids, Solar-thermal, Coal-IGCC
>20%	Microturbine, Fuel Cells

**Uncertainty Analysis**

Any future-oriented economic assessment must account for uncertainties in the key input variables. Key uncertainties in projecting future generation costs include fuel costs, future technology cost and performance, resource variability and others. An uncertainty analysis was conducted using a probabilistic approach based on the “Crystal Ball” software package. All uncertainty factors are estimated in a band, and generating costs were calculated by Monte Carlo Simulation. A summary of the uncertainty analysis process is graphically presented in outputs from the “Crystal Ball” analysis including maximum, average and minimum levelized cost of electricity (Table 1.2).

**Table 1.2: Uncertainty Variables for Analysis**

	Inputs	Distribution (Default Value)		
		Minimum	Probable	Maximum
Common Conditions	Equipment			
	Civil			
	Engineering	Yr 2005-20%		Yr 2005 + 20%
	Erection	Yr 2010-25%	100%	Yr 2010 + 25%
	Contingency	Yr 2015-30%		Yr 2010 + 30%
	Fix O&M			
	Variable O&M			
Particular Conditions	Fuel Price	Oil, Gas: +100%, 35% Coal: +65%, -20%		
	Capacity Factor	CF for Renewable Technology (Solar-PV, Wind, PV-wind, Solar-thermal, Hydro): ± (2-10%)		

Note: Each distribution is cut with 95% reliability.

**Example: Capital Cost of Coal IGCC (in 2015)**

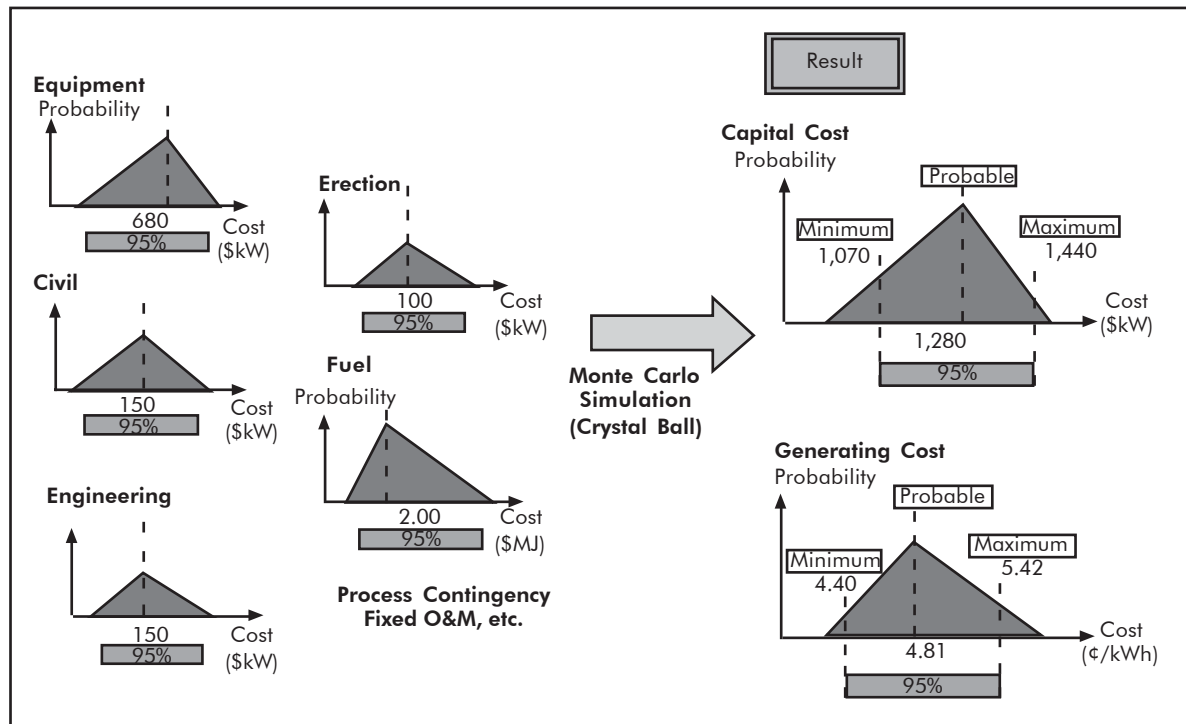

## **Capacity Factor**

Capacity factor is the ratio of the actual energy generated in a given period relative to the maximum possible if the generator produced its rated output all of the time. Capacity factor is a key performance characteristic, as it expresses the productive output relative to the installed capacity and allows for capital costs to be expressed in levelized terms. We chose capacity factor rather than availability factor or other expressions of productive output per unit installed capacity because it is unambiguous and universally applicable.

## **Deployment Venue**

Capital cost and operating costs for a given power generation technology can vary considerably depending on where the power plant is located. In order to simplify the economic assessment, we express all capital costs and operating costs on the basis that the power plant is constructed in India. This allows extrapolation of capital and operating costs to other deployment venues based on a comparison of available national or regional benchmarks (for example, labor rates and fuel delivery surcharges).

## **Fuel Price Forecasts**

Fuel prices used throughout this report are based on the IEA World Energy Outlook 2005 forecast. We have levelized the forecast fuel price over the life span of each generating technology assessed, taking into account forecast average price. We incorporated price fluctuations by allowing a price range of up to 200 percent of forecast base fuel price. The resulting fuel price range for each time frame and each fuel is shown in Table 1.3.

## **Regional Adjustments**

An objective of the assessment was to express all costing information (capital costs and generating costs) for the 22 power generation options on the same basis, including assumed location and fuel supply arrangements. However, all infrastructure capital and operating costs – engineering, equipment and material, construction, O&M, fuel, even contingency – vary depending on location. A particularly area-sensitive cost variable is labor, which is an important determinant of both construction and O&M costs.

**Table 1.3: Fossil Fuel Price Projections**

<b>Crude Oil</b>				
FOB Price of Crude Oil		2005	2010	US\$/bbl (US\$/GJ) 2015
Crude Oil (Dubai, Brent, WTI)	Base	53 (9.2)	38 (6.6)	37 (6.5)
	High	–	56 (9.8)	61 (10.6)
	Low	–	24 (4.2)	23 (4.0)
<b>Coal</b>				
FOB Price of Coal		2005	2010	US\$/ton (US\$/GJ) 2015
Coal (Australia)	Base	57 (2.07)	38 (1.38)	39 (1.42)
	High	–	53 (1.92)	56 (2.04)
	Low	–	30 (1.10)	30 (1.10)
<b>Natural Gas</b>				
FOB Price of Natural Gas		2005	2010	US\$/MMBTU (US\$/GJ) 2015
Gas (U.S., European)	Base	7.5 (7.1)	5.1 (4.8)	5.1 (4.8)
	High	–	7.0 (6.6)	7.6 (7.2)
	Low	–	4.0 (3.8)	3.3 (3.1)

Note: “–” means no cost needed.

Location factors for the Asian region are provided in Figure 1.1. In addition to the data presented for developing countries, we also provide data for one industrial economy (Japan). The data shown in Figure 1.1 suggest that the variation in costs of engineering, equipment and materials is quite small when procurement is done under the international competitive bidding (ICB) or comparable guidelines. The labor costs vary from region to region, depending on the gross domestic product (GDP) and per capita incomes.<sup>5</sup>

## Study Limitations

This study is limited in several ways. First, it is time-bound. It does not reflect new technology developments or new secular trends that have emerged since the terms of reference were

<sup>5</sup> Useful references on this topic include: <http://www.cia.gov/cia/publications/factbook>, <http://hdr.undp.org/reports/global/2003>, [http://www.worldfactsandfigures.com/gdp\\_country\\_desc.php](http://www.worldfactsandfigures.com/gdp_country_desc.php), <http://stats.bls.gov/fls/hcompsupptabtoc.htm>, <http://www.ggdc.net/dseries/totecon.html>, and <http://www-ilo-mirror.cornell.edu/public/english/employment/strat/publ/ep00-5.htm>.

**Figure 1.1: JSIM Labor Factor by Region**

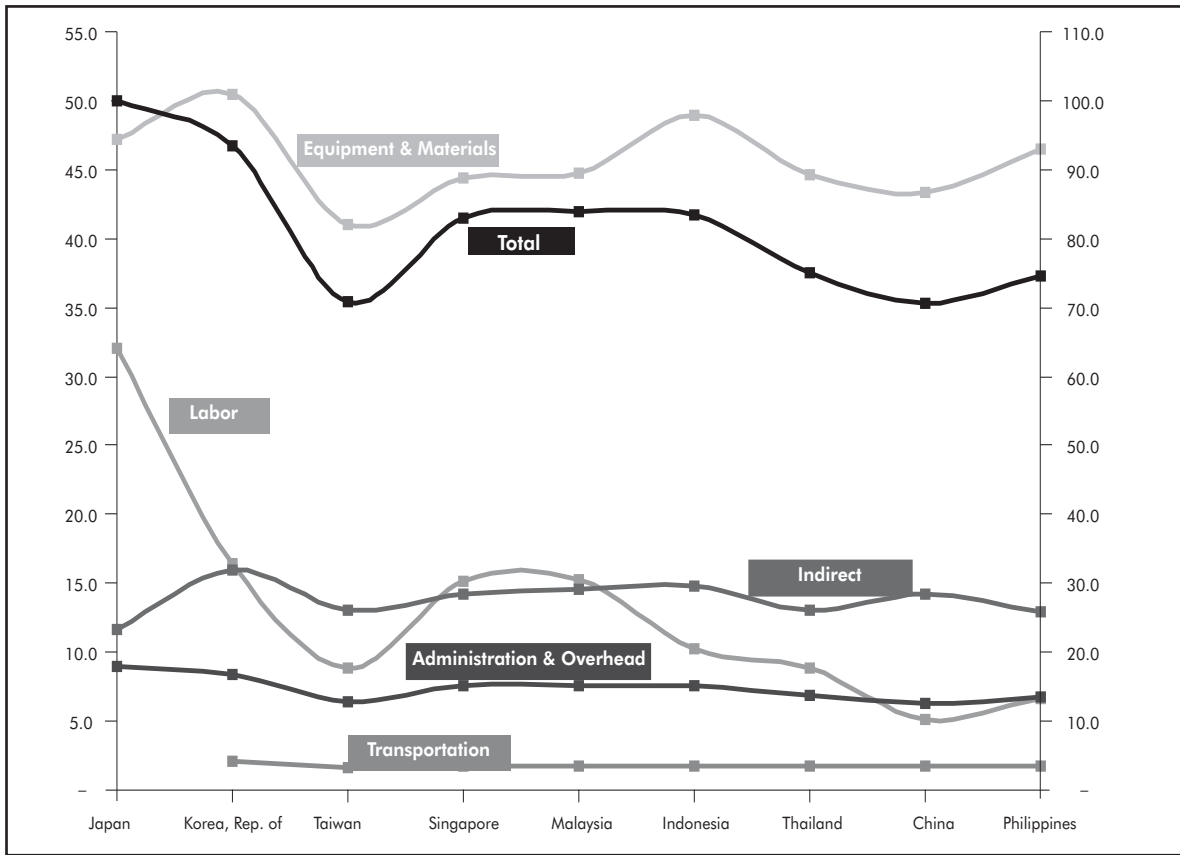

Source: Japan Society of Industrial Machinery Manufacturers, 2004.

formalized. At the same time, unpredictable fluctuations of generation facilities' prices caused by an excessive unbalance in demand-supply condition are not considered. Secondly, it is bound by the available literature. We drew from secondary sources and performed no new technology or analytic development. In some cases, especially with emerging technologies, available literature or project experience is limited. Thirdly, the results are generalized and represent averaging over what are important specific conditions (although the uncertainty analysis accounts for this somewhat). Any application of these results must be done based on modification to suit local, actual conditions.

# 2. Power Generation Technology Assessment

This section presents the detailed technology descriptions and results of the technical and economic assessment for 22 selected off-grid, mini-grid and grid electrification technology applications. The technology descriptions are presented in three groups – renewable power generation technologies, conventional power generation technologies and emerging power generation technologies.

## **Renewable Technologies**

Six major renewable energy technologies (RETs) are reviewed in this study – solar photovoltaic (SPV), wind electric, solar thermal electric, geothermal electric, biomass electric and hydroelectric. Within each of these broad categories, there are one, and sometimes several configurations corresponding to combinations, permutations (including size) and hybrid arrangements of the individual technologies.

### **Solar Photovoltaic Power Systems**

SPV systems utilize semiconductor-based materials (solar cells) which directly convert solar energy into electricity. First developed in the 50s, SPV technology has steadily fallen in price and has gained many niche applications, notably as satisfying remote power needs for telecommunications, pumping and lighting. SPV systems have many attractive features, including modularity, no fuel requirements, zero emissions, no noise and no need for grid connection. SPV systems can be classified according to three principal applications (Figure 2.1):

- Stand-alone solar devices purpose-built for a particular end use, for example, cathodic protection, home power and water pumping;
- Small solar power plants designed to provide village-scale electricity; and
- Grid-connected SPV power plants.

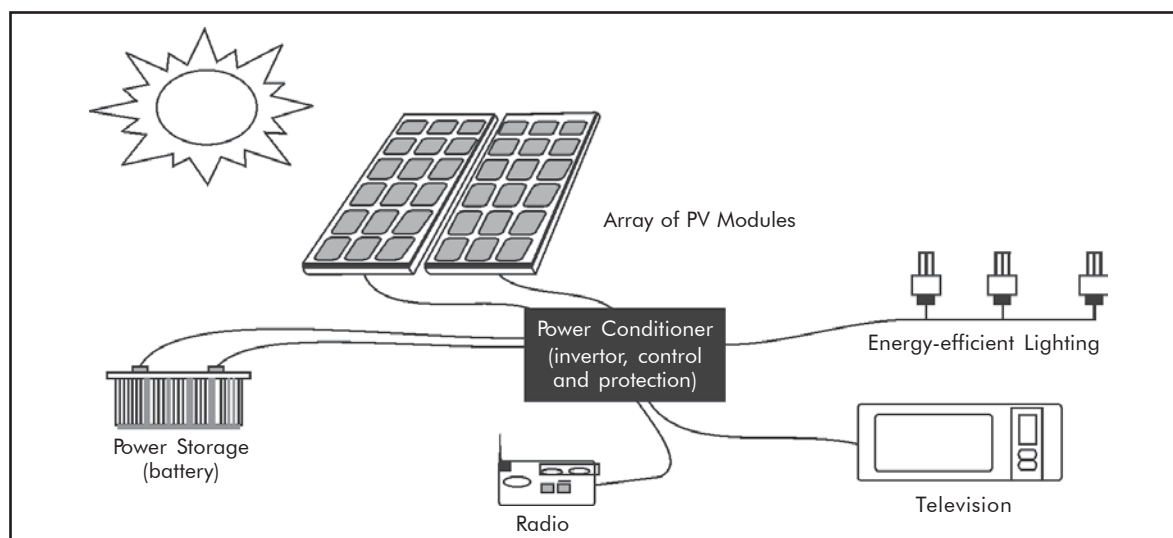
**Figure 2.1: Stand-alone Solar Photovoltaic System**

Source: DOE/EPRI.

For the economic assessment, we chose several common SPV configurations and sizes suitable for a range of off-grid, mini-grid and grid applications (Table 2.1).

**Table 2.1: Solar PV Configurations Assessed**

Description	Small SPV Systems		SPV Mini-grid Power Plants	Large Grid-connected SPV Power Plant
Module Capacity	50 W <sub>p</sub>	300 W <sub>p</sub>	25 kW	50 MW
Life Span Modules	20 Years	20 Years	25 Years	25 Years
Life Span Batteries	5 Years	5 Years	5 Years	NA
Capacity Factor	20%	20%	20%	20%

Note: NA = Not applicable.

Our economic assessment assumes a 20 percent capacity factor, based on 4.8 daily hours of peak power output. As SPV module costs comprise 50+ percent of the costs, we note that these costs have fallen from US\$100 per W<sub>p</sub> in 1970 to US\$5 in 1998.<sup>6</sup> Our economic assessment assumes continued decreases in SPV costs of 20 percent between 2004 and 2015 based on technology advancement and growing production volume (Table 2.2).<sup>7</sup> Japan, one of the major markets for solar PV and a major manufacturer of SPV modules, is

<sup>6</sup> The challenges of cold climates PV in Canada's North, *Renewable Energy World*, July 1998, pp 36-39.

<sup>7</sup> SPV sales have increased from 200 MW in 1999 to 427 MW in 2002 and to above 900 MW in 2004.



forecasting production cost reductions from 100 yen (¥)/W<sub>p</sub> today to ¥75/W<sub>p</sub> by 2010 and ¥50/W<sub>p</sub> by 2030. The solar PV industry in Europe and the United States is targeting costs of US\$1.5-2.00/W<sub>p</sub> within 10 years, based on technological improvements as well as a growth in production volumes of 20-30 percent.

**Table 2.2: Targets for SPV Future Costs**

Cost	Europe	United States	Japan	India
2004 SPV Module Costs	€5.71/W <sub>p</sub>	US\$5.12/W <sub>p</sub>	¥100/W <sub>p</sub>	Rs 150/W <sub>p</sub>
Target Cost in 2010	€1.5-2/W <sub>p</sub>	US\$1.5-2/W <sub>p</sub>	¥75/W <sub>p</sub>	Rs 126/W <sub>p</sub> * (@2.75/W <sub>p</sub> )
Expected Cost in 2015	€0.5/W <sub>p</sub>	NA	¥50/W <sub>p</sub> (in 2030)	Rs 92/W <sub>p</sub> * (US\$2/W <sub>p</sub> )

Note: NA = Not applicable.

## Wind Power Systems

Wind turbines are classified into two types: small (up to 100 kW) and large. Small wind turbines are used for off-grid, mini-grid and grid-connected applications, while large wind turbines are used exclusively for grid-connected power supply. Wind turbine components include the rotor blades, generator (asynchronous/induction or synchronous), power regulation, aerodynamic (Yaw) mechanisms and the tower. Wind turbine component technology continues to improve, including the blades (increasing use of C epoxy and other composite materials to improve the weight/swept area ratio); generators (doubly-fed induction generators and direct-drive synchronous machines providing improved efficiency over broader wind speed ranges); power regulation (through active stall pitch controls); and towers (tubular towers minimize vibration, allow for larger machines to be constructed and reduce maintenance costs by providing easier access to the nacelle).

The major applications for small wind turbines are charging batteries and supplying electrical loads in direct current (DC) (12 or 24 volts [V]), bus-based off-grid power systems. When configured with a DC alternating current (AC) inverter and a battery bank, the small wind turbine can deliver power to a village or district mini-grid, usually in a hybrid configuration with diesel generators or SPV.

Design assumptions regarding wind turbines with output from 0.3 kW to 100,000 kW are shown in Table 2.3. Capacity factors depend on wind speeds at a given location and can vary from 20 percent to 40 percent. An average value of 25 percent is assumed with the uncertainty analysis incorporating the broader range of likely location-specific capacity factors.

**Table 2.3: Wind Turbine Performance Assumptions**

Capacity	300 W	100 kW	10 MW	100 MW
Capacity Factor (%)	25	25	30	30
Life Span (year)	20	20	20	20
Annual Gross Generated Electricity (MWh)	0.657	219	26,280	262,800

The costs of wind generators have been decreasing over the years, a trend which is forecast to continue (Figure 2.2). The Electric Power Research Institute (EPRI) projects the costs for 10 mega watt (s) (MW) plant will decrease by 10 percent in 2010 and 20 percent by 2015.<sup>8</sup> The EPRI values are likely conservative, as today's costs for large wind turbines in India, Germany, Denmark and Spain are in the 800 to 1,200 euros (€)/kW.<sup>9</sup> In our cost projections, we have elected to use the European cost projections as a lower bound and EPRI cost projections as an upper bound.

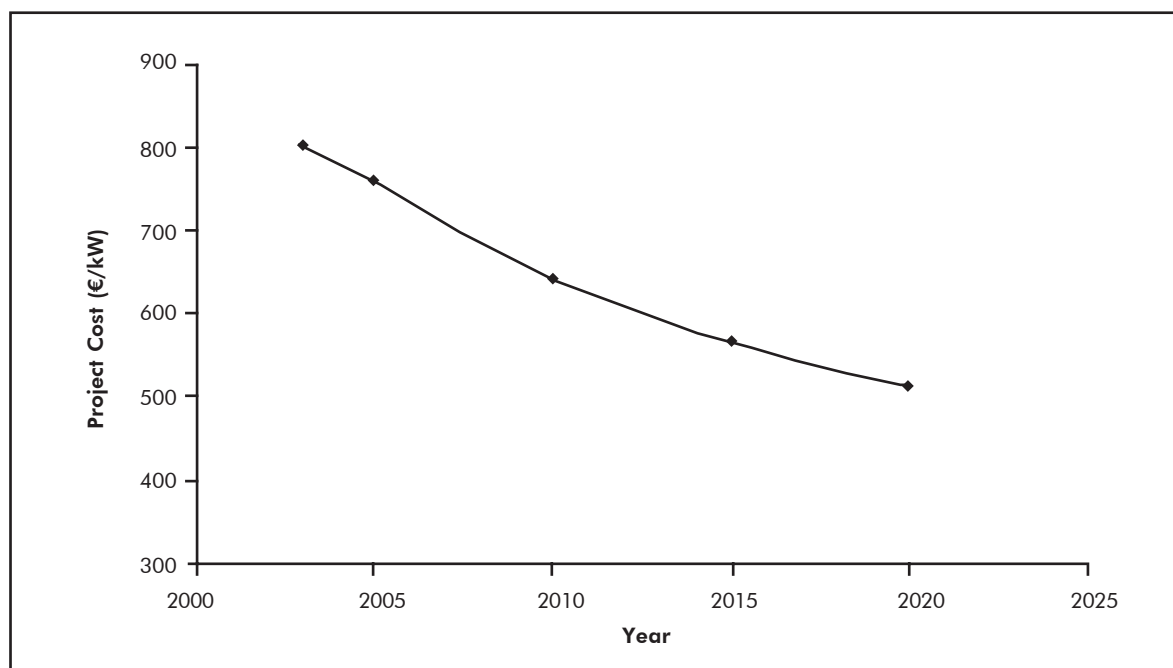
**Figure 2.2: Projected Wind Power Costs, 2000-25**

Source: European Wind Energy Association.

<sup>8</sup> Renewable Energy Technical Assessment Guide – TAG-RE: 2004, EPRI, 2004.

<sup>9</sup> Wind Energy – The Facts, Vol. 2: Costs and Prices, EWEA, 2003.

### SPV-wind Hybrid Power Systems

Power generation schemes using a combination of SPV and wind energy can take advantage of the complementary availability of the solar and wind resources. A hybrid SPV-wind power configuration allows each renewable resource to supplement the other, increasing overall reliability without having to resort to other backup sources such as diesel generators. This is a potentially attractive arrangement for small loads (100 kW or less) in an off-grid or mini-grid configuration. Solar-wind hybrid systems have been successfully deployed for island mini-grids, remote facilities and small buildings.

SPV-wind hybrid systems, in practice, can be configured in two ways, depending on how the inverter/controller and battery storage are arranged. A common arrangement is an AC mini-grid with DC-coupled components (Figure 2.3). The inverter can receive both DC power from the SPV array and AC power from the wind turbine, and deliver these inputs to the battery storage. This configuration is effective for village applications (0.5 to 5 kW).

Another arrangement for larger loads (3 to 100 kW) is a modular AC system, which comprises a traditional AC system but incorporates inverters for battery storage and SPV power input. For the economic assessment of SPV-wind hybrids, we use a system life of 20 years, and a 30 percent capacity factor. Cost projections for these hybrid systems are assumed to follow the same trajectory as projected for the individual technologies (for example, SPV and wind). Two size ranges – 300 W, corresponding to an off-grid application and 100 kW, corresponding to a mini-grid application – are examined.

**Figure 2.3: SPV-wind DC- and AC-coupled Arrangement**

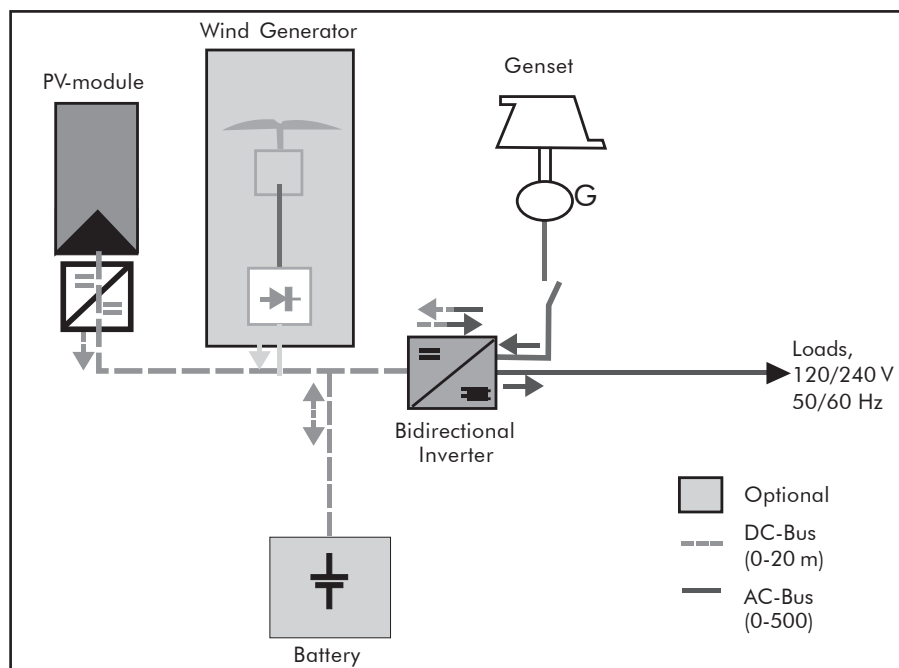

Source: DOE/EPRI.

## Solar-thermal Electric Power Systems

Generating power from solar energy through thermal-electric power conversion requires collecting solar energy in concentrated densities sufficient to power a heat engine. Many solar energy concentrating schemes have been tried, including parabolic dish collectors, parabolic trough collectors and central receivers. Only the parabolic trough configuration has progressed toward commercial application, albeit slowly (Figure 2.4). There are several parabolic trough-based solar-thermal electric projects ranging from 10-50 MW in the planning stages, and this is the only solar-thermal electric system considered here.<sup>10</sup>

**Figure 2.4: Solar-thermal Electric Power Plant**

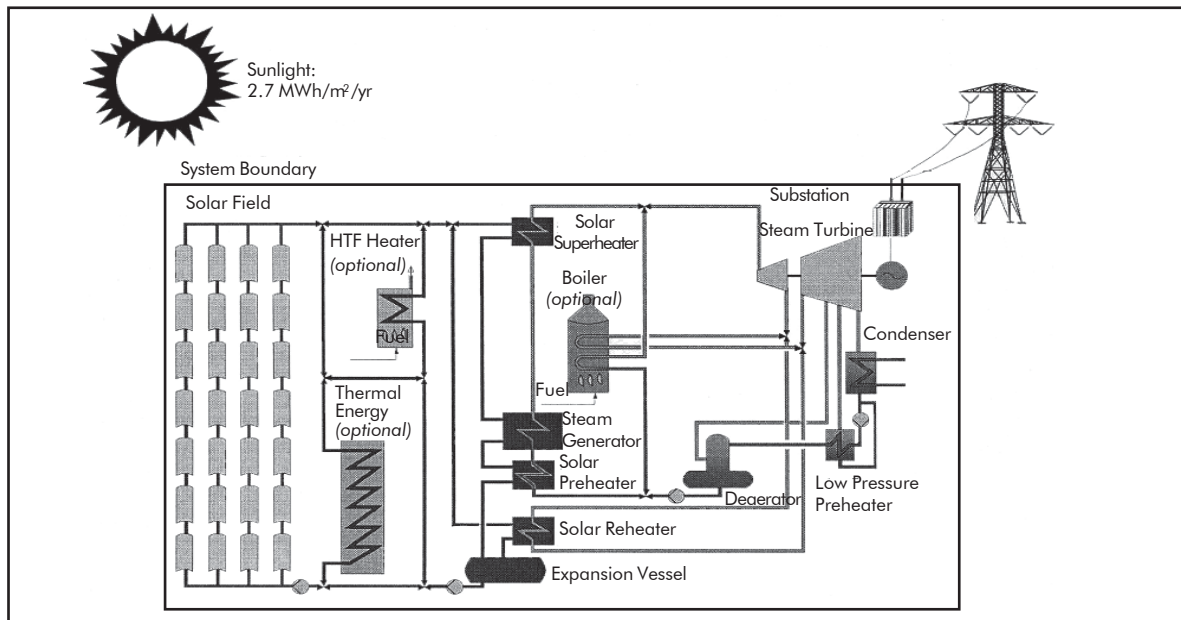

Source: DOE/EPRI.

A parabolic trough concentrator tracks the sun with a single-axis mechanical tracking system oriented east to west. The trough focuses the solar insolation on a receiver located along its focal line. The concentrators are deployed in numbers sufficient to generate the required amount of thermal energy, which is transported via a heat transfer fluid (typically high temperature oil) to a central power block, where the heat generates steam. The power block consists of steam turbine and generator, turbine and generator auxiliaries, feed-water and condensate system. A solar-thermal electric power plant, which incorporates thermal storage, can have a higher capacity factor, but at increased cost. Here we examine a grid-connected 30 MW solar-thermal electric power plant with and without thermal storage (Table 2.4).

<sup>10</sup> See, for example, *The World Bank Project Information Document, Arab Republic of Egypt Solar Thermal Power Project. Report No. AB662.*

Cost and performance estimates prepared by the United States Department of Energy's (USDoE) National Renewable Energy Laboratory (NREL) are used in the analysis. An NREL forecast of possible solar-thermal electric cost reductions, based on technology improvement projections and scale-up, projects a 15 percent cost reduction by 2010 and 33 percent by 2015. We take these projections as an upper bound and assume a more conservative cost reduction of 10 percent and 20 percent by 2010 and 2015, respectively.

**Table 2.4: Solar-thermal Electric Power System Design Parameters**

Capacity	30 MW (without thermal storage)	30 MW (with thermal storage)
Capacity Factor (%)	20	50
Life Span (year)	30	30
Gross Generated Electricity (GWh/year)	52	131

Source: NREL.

### Geothermal Electric Power Systems

The principal geothermal resources under commercial development are naturally-occurring hydrothermal resources. Hydrothermal reservoirs consist of hot water and steam found in relatively shallow reservoirs. Hydrothermal reservoirs are inherently permeable, which means that fluids can flow out of wells drilled into the reservoir.

Commercial exploitation of geothermal systems in developing economies is constrained by availability of the resource, and the need for geothermal resource prospecting and exploitation capacity. Countries which have successfully developed geothermal power plants (the Philippines, Mexico, Indonesia, Kenya and El Salvador) tend to be in regions with many hydrothermal manifestations (for example, geysers, hot springs) and where there has been intensive local capacity-building, and an influx of needed specialists.

We assess geothermal power systems in three sizes – a 200 kW binary hydrothermal application suitable for mini-grid applications and two larger sizes (20 MW binary hydrothermal and 50 MW flash hydrothermal) suitable for grid applications. Table 2.5 provides design assumptions for these generic geothermal power plants while Figure 2.5 provides a schematic for a typical binary hydrothermal electric power plant.

**Table 2.5: Design Assumptions for Geothermal Power Plants**

	Binary Hydrothermal	Binary Hydrothermal	Flash Hydrothermal
Capacity	200 kW	20 MW	50 MW
Capacity Factor (%)	70	90	90
Geothermal Reservoir Temperatures	125-170°C	125-170°C	>170°C
Life Span (year)*	20	30	30
Net Generated Electricity (MWh/year)	1,230	158,000	394,200

\* Although the plant life span is 20-30 years, wells will be depleted and new wells be drilled much before that time. An allowance for this additional drilling is included in the generating cost estimates.

Large geothermal plants operate as base-loaded generators with capacity factors comparable to conventional generation. Smaller plants for mini-grid applications will have lower capacity factors (30-70 percent), due mainly to limitations in local demand. Although geothermal power plants are renewable, they are not emission-free. Hydrogen sulfide (H<sub>2</sub>S) emissions (no more than 0.015 kilograms (s) (kg)/MWh) are common, but can be mitigated with removal equipment. Carbon dioxide (CO<sub>2</sub>) emissions compare favorably to fossil fuel plants.

Unlike most other RE resources, the extractive nature of geothermal projects results in longer development time and a particular project development cycle unlike that of other

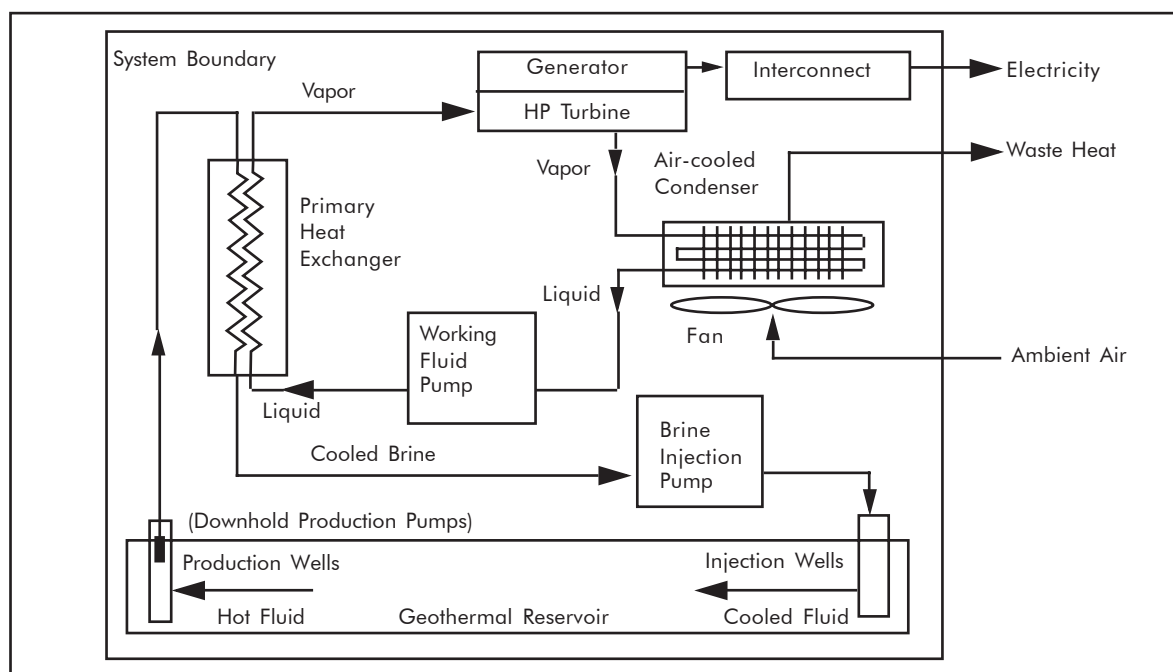
**Figure 2.5: Binary Hydrothermal Power Plant Schematic**

Source: DOE/EPRI.

technologies assessed. Table 2.6 provides a breakdown of the capital cost estimates organized by the development sequence (for example, exploration, confirmation, main wells), showing that fully one-quarter of the capital costs is expended before ground is even broken on the geothermal power plant. For this reason, we assume extra contingency costs for this option.

**Table 2.6: Geothermal Power Capital Costs by Project Development Phase (2004 US\$)**

<i>Item</i>	<i>200 kW Binary Plant</i>	<i>20 MW Binary Plant</i>	<i>50 MW Flash Plant</i>
Exploration	300	320	240
Confirmation	400	470	370
Main Wells	800	710	540
Power Plant	4,250	2,120	1,080
Other	1,450	480	280
<b>Total</b>	<b>7,200</b>	<b>4,100</b>	<b>2,510</b>

It is difficult to predict future prices for geothermal power systems. Although there have been significant long-term price declines since 1980 (about 2 percent per year for power plants), recent increases in oil prices have driven up the cost of geothermal wells. Many industry analysts contend that research and large-scale deployment can resume a downward trend in geothermal power costs. We assume a flat cost trajectory for this technology, and capture the potential for significant cost reductions in the uncertainty analysis.<sup>11</sup>

### **Biomass Gasifier Power Systems**

A biomass gasifier converts solid biomass material (woody cellulose and other organic solids) into a combustible gas mixture known as “producer gas” with relatively low thermal value (1,000-1,100 (Kilo Calorie (s) [kcal]/Cubic Meter [m<sup>3</sup>])). The gasification process involves successive drying, pyrolysis, oxidation/combustion and reduction in a staged chamber under different temperatures and pressures. The producer gas (containing 52 percent Nitrogen [N], 12 percent CO<sub>2</sub>, 2 percent methane (CH<sub>4</sub>), 20 percent carbon monoxide [CO] and 14 percent hydrogen [H]) is then filtered, scrubbed and treated before being combusted in a standard engine-generator configuration (Figure 2.6).

<sup>11</sup> We draw from the EPRI work on RE to establish a range of expected capital cost reductions (generally, -20% and +10%) over the study period.

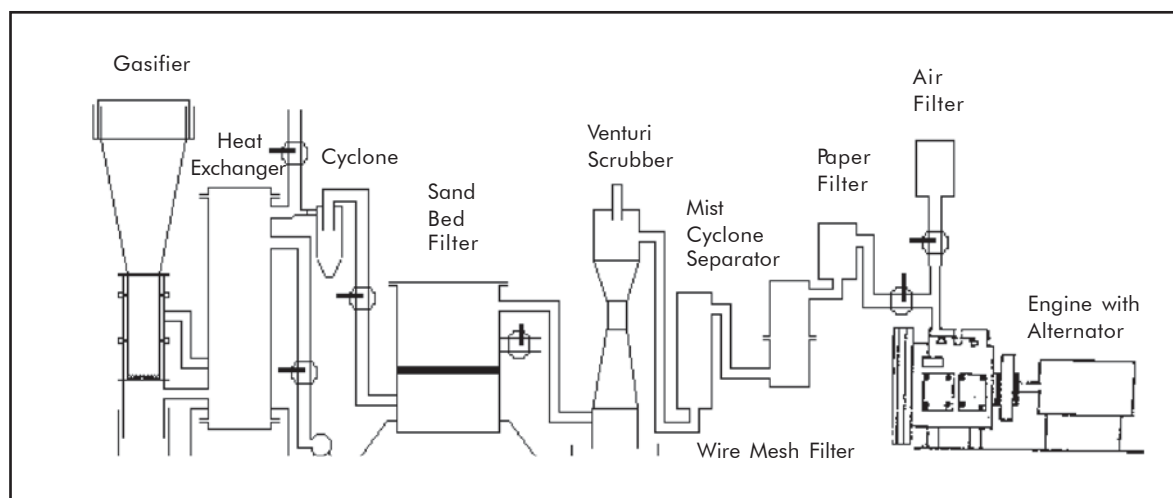
**Figure 2.6: Biomass Gasification Process Schematic**

Types of gasifiers in use include down draft, updraft and cross draft, fluidized bed and pyrolyzers. Choice of gasifier design affects the thermal value of the produced gas and its inert contents (tar, ash, particulates, CO), as well as the amount of treatment necessary before it can be used. Fuel cost is the most important parameter in estimating the generation costs of any biomass-based power generation technology. The cost of biomass depends on many parameters, including project location, type of biomass feedstock, quantity required and present and future alternative use. We assess two sizes/applications of biomass gasifier technology – a small (100 kW) system applicable to mini-grid applications and a large (20 MW) system applicable to grid-connected use. Table 2.7 gives details of the design and performance parameters we assume for the economic assessment of these two cases.

**Table 2.7: Biomass Gasifier Design Assumptions**

Capacity (kW)	100 kW	20 MW
Fuel	Wood/Wood Waste/Agro Waste	Wood/Wood Waste/Agro Waste
Calorific Value of Fuel	4,000 kcal/kg	4,000 kcal/kg
Capacity Factor	80%	80%
Producer Gas Calorific Value	1,000-1,200 kcal/Nm <sup>3</sup>	1,000-1,200 kcal/Nm <sup>3</sup>
Life Span of System	20 Years	20 Years
Specific Fuel Consumption	1.6 kg/kWh	1.5 kg/kWh



Environmental impacts associated with combustion of the biomass gas are assumed to be constrained by emissions control regulation, consistent with the World Bank standards. The future cost of these systems will likely be less than at present, as biomass gasification has considerable potential for technology improvements and economies of mass production. Our economic assessment assumes that improvements in the areas of low tar-producing gasifiers and improved cleaning and cooling equipment will yield a 5 percent reduction in capital costs by 2010, and a 10 percent reduction by 2015.

### Biomass-steam Electric Power Systems

A biomass-steam electric power system is for the most part indistinguishable from other steam electric power systems (for example, oil and coal) that combust fuel in a boiler to generate steam for power production. A biomass-fired boiler generates high-pressure steam by direct combustion of biomass in a boiler. There are two major types of biomass combustion boilers – pile burners utilizing stationary or traveling grate combustors and fluidized-bed combustors. A schematic diagram of direct-fired biomass electricity generating system is shown in Figure 2.7.

**Figure 2.7: Biomass-fired Steam Electric Power Plant**

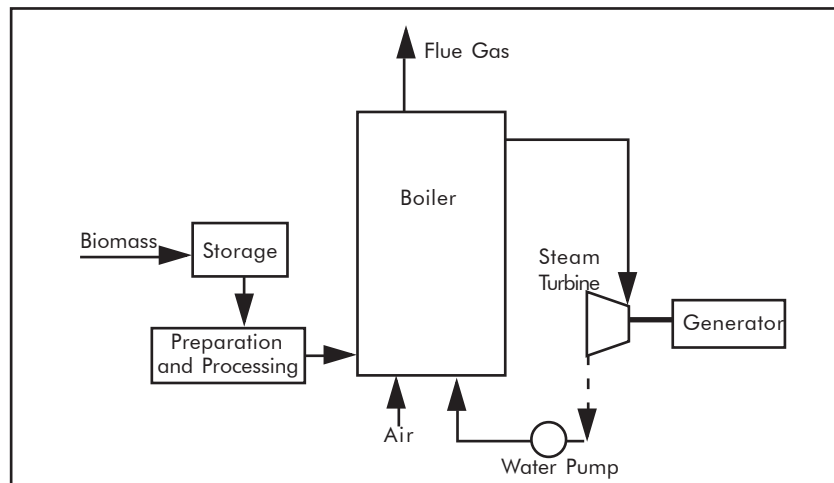

In a pile burner combustion boiler, the biomass burns on a grate in the lower chamber, releasing volatile gases which then burn in the upper chamber. Current biomass combustor designs utilize high efficiency boilers and stationary or traveling grate combustors with automatic feeders that distribute the fuel onto a grate to burn. Fluidized-bed combustors are the most advanced biomass combustors. In a fluidized-bed combustor, the biomass fuel is in a small granular form (for example, rice husk) and is mixed and burned in a hot bed of sand. Injection of air into the bed creates turbulence, which distributes and suspends the fuel while increasing the heat transfer and allowing for combustion below the temperature that normally creates nitrogen oxides ( $\text{NO}_x$ ) emissions.

We assess only one biomass steam electric configuration – a 50 MW grid-connected power plant with a capacity factor and performance characteristics comparable to that of a conventional central station power plant (Table 2.8).

**Table 2.8: Biomass-steam Electric Power Plant Design Assumptions**

Capacity	50 MW
Capacity Factor (%)	80
Fuel	Wood/Wood Waste/Agro Waste
Calorific Value of Fuel	4,000 kcal/kg
Specific Fuel Consumption	1.5 kg/kWh
Life Span (year)	20
Gross Generated Electricity (GWh/year)	350

A biomass-steam electric power plant will have emission characteristics similar to that of any other fossil fuel-fired plant, other than SOs. Environmental impacts are assumed to be constrained by emissions control regulation, consistent with the World Bank standards. The future costs for biomass-steam generation projects are expected to drop as a result of increased market penetration and technology standardization. Our assessment assumes a modest reduction of 3 percent by 2010, and 5 percent by 2015. The key uncertainty in estimating biomass-based power generation technology is the cost of biomass, which depends on many parameters including location, type of biomass feedstock, quantity required and present and future alternative use.

### **Municipal Waste-to-power via Anaerobic Digestion System**

Municipal waste can be converted to electric power in two ways: (i) by mass burning in a waste-to-energy facility; or (ii) through anaerobic digestion (AD) of the organic fraction of solid waste, either in closed digesters or, in situ, in landfills. The biogas product of AD comprises CH<sub>4</sub>, CO<sub>2</sub>, H<sub>2</sub> and traces of H<sub>2</sub>S. The biogas yield and the CH<sub>4</sub> concentration depend on the composition of the waste, and the chemical and collection efficiency of the anaerobic digester or landfill design. After treatment to remove undesirable trace gases, the biogas can be used for thermal applications or in gas engines to generate electricity. Our economic assessment will be of a waste-to-power system in which biodegradable matter is anaerobically digested in a landfill (Figure 2.8).

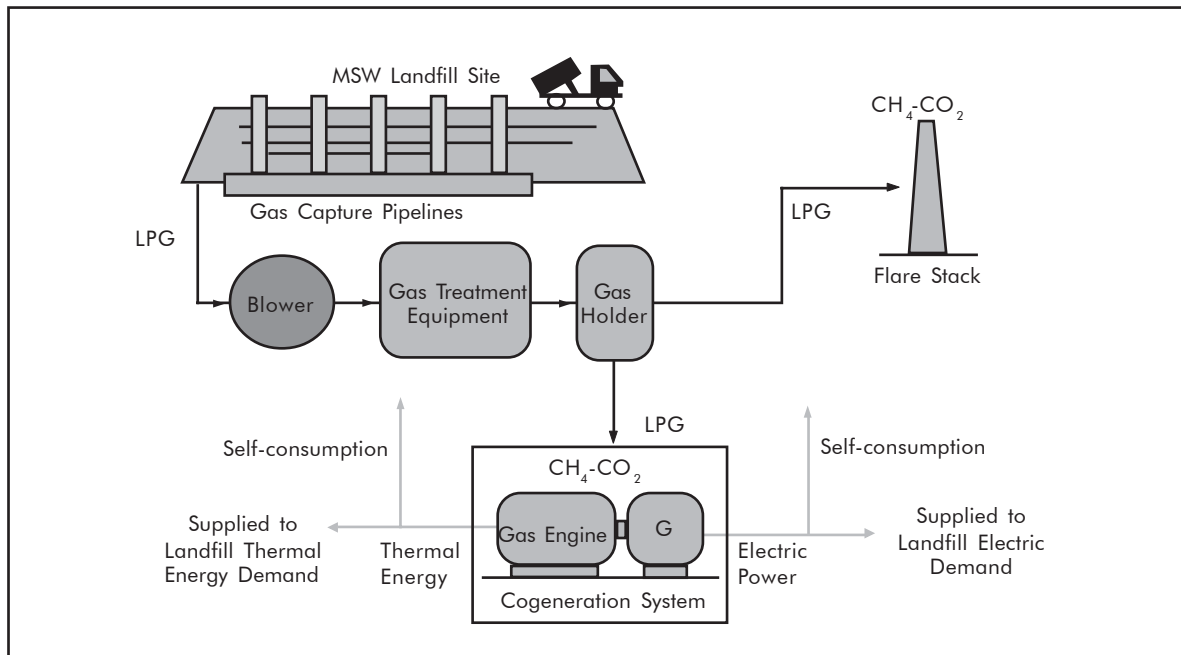
**Figure 2.8: Municipal Waste-to-power via Anaerobic Digestion**

Source: Ministry of Environment, Government of Japan.

We examine only one configuration, that of a large (5 MW), grid-connected waste-to-energy power plant with performance parameters as shown in Table 2.9.

**Table 2.9: Municipal Waste-to-power System Characteristics**

Capacity	5 MW
Capacity Factor (%)	80
Fuel-type	Municipal Solid Waste
Life Span (year)	20
Gross Generated Electricity (GWh/year)	35

Environmental impacts of the digestion process should be minimal, as any  $H_2S$  or other organic volatiles can be scrubbed before utilization of the biogas product. Waste-to-energy projects have highly desirable net Greenhouse Gas (GHG) impacts, as  $CH_4$  emissions that might otherwise emanate from landfill sites are sequestered.

We project a decrease in both capital and generating costs of waste-to-power systems in future, as significant reductions are likely from technological development and domestic

manufacture of plant equipment. We assume these trends will result in a decrease in equipment cost of 15 percent by 2015. Other uncertainties including any “tipping costs” for the waste material are included in the uncertainty analysis.

**Biogas Power Systems**

A biogas electric power system operates in a manner similar to the municipal waste-to-power system described above, with biomass feedstock in the form of animal dung, human excreta and leafy plant materials anaerobically digested to produce a highly combustible biogas comprising 60 percent CH<sub>4</sub> and 37 percent CO<sub>2</sub>, with traces of sulfur dioxide (SO<sub>2</sub>) and 3 percent H. A 25-kg batch of cow dung digested anaerobically for 40 days produces 1 m<sup>3</sup> of biogas with a calorific value of 5,125 kcal/m<sup>3</sup>. The remaining slurry coming out of the plant is rich in manure value and is a valuable fertilizer. Typical biogas constructions include the floating drum-type and the fixed dome-type (Figure 2.9). Both configurations have inlet and outlet chutes and a digester which operates at a constant gas pressure throughout, that is, the gas produced is delivered at the point of use at a predetermined pressure. The output of the biogas plant can be used for cooking or any other thermal application.

**Figure 2.9: Fixed Dome Biogas Plant**

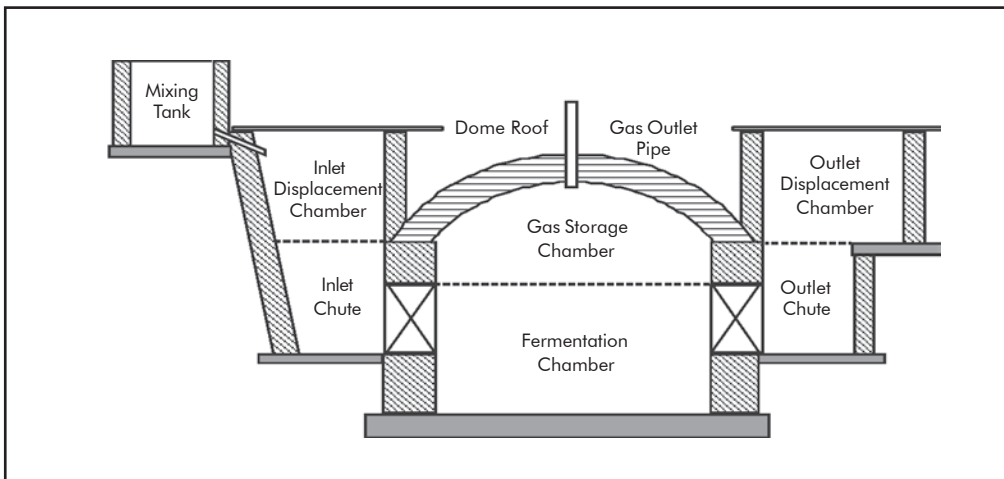

The simplicity and modularity of design, construction and operation and the variety of uses for the biogas product, make this technology well suited for small-scale applications. Therefore, our economic assessment focuses on a biogas system sized to provide sufficient power for a 60 kW engine operating in a mini-grid application. We assume a capacity factor of 80 percent, which is achieved by properly sizing the plant and ensuring sufficient feedstock into the biogas system (Table 2.10).

**Table 2.10: Biogas Power System Design Assumptions**

Capacity	60 kW
Capacity Factor (%)	80
Life Span (year)	20
Gross Generated Electricity	0.42 GWh

As with the other biomass applications, the GHG impacts are highly positive, as the design sequesters and utilizes CH<sub>4</sub> that would otherwise escape to the atmosphere. Since biogas technology is very simple, uses local resources and has been in commercial operation for a long time, we do not project any dramatic reduction in future system costs.

### Micro- and Pico-hydroelectric Power Systems

Micro-hydro power projects are usually “run-of-the-river” (RoR) schemes that divert some of the water flow through civil works, for example, an intake weir, fore bay, and, for micro-hydro options, a penstock. Such schemes require no water catchments or storage, and thus have minimal environmental impacts. A drawback of such a scheme is seasonal variation in flow, making it difficult in some cases to balance load with power output. Because micro- and pico-hydro systems are simple, scaleable, reasonably reliable and low cost, they provide a source of cheap, independent and continuous power without the need for environmental safeguards.

A micro-hydroelectric power plant comprises civil works and electro-mechanical equipment. Civil works include the weir, which provides a regulated discharge to the feeder channel; the feeder channel, constructed of concrete with desilting tanks along its length; the fore bay, a concrete or steel tank designed providing a steady design head for the project; and the penstock, a steel, concrete or PVC pipe, sized to provide a steady and laminar water flow into the turbine (Figure 2.10). The electro-mechanical works include a Pelton or Turgo turbine (for high-head applications) or a Kaplan or Francis turbine (for low-head applications); an induction or synchronous generator (induction for low power outputs and synchronous for large-capacity units); and an electronic load governor or electronic load controller, depending on whether the turbine and generator operate at full power or varying load conditions.

A pico-hydroelectric power plant is much smaller than a micro-hydro (for example, 1 kW or 300 W), and incorporates all of the electro-mechanical elements into one portable device. A pico-hydro device is easy to install, with 300 W-class pico-hydroelectric units typically

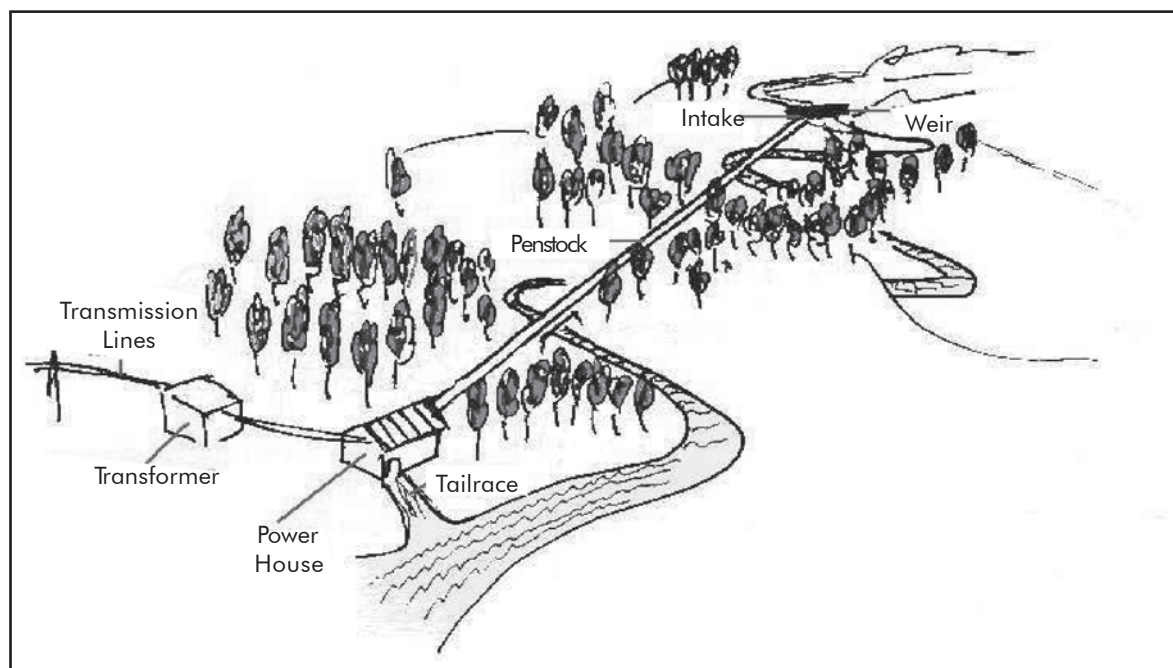
**Figure 2.10: Micro-hydroelectric Power Scheme**

Source: <http://www.microhydropower.net>.

installed by the purchaser because of the low 1-2 meters (m) head requirement, while larger (1 kW) units require a small amount of construction work to accommodate somewhat higher (5-6 m) head requirements. They are typically installed on the river or stream embankment and can be removed during floods or low flow periods. The power output is sufficient for a single house or small business. Earlier pico-hydro devices were not equipped with any voltage or load control, which was a drawback as it produced lighting flicker and reduced appliance life. Newer pico-hydro machines come with embedded power electronics to regulate voltage and balance loads.

For our economic assessment, we chose three design points – a micro-hydro scheme of 100 kW suitable for a mini-grid application and two pico-hydro schemes (1 kW and 300 W) suitable for off-grid applications (Table 2.11). As with other renewable power systems, capacity factor varies according to site conditions and loading. We assume an average capacity factor and incorporate wider variations in the uncertainty analysis.

There has been very little variation in the equipment cost of micro- and pico-hydro electric equipment. Our economic assessment assumes that the capital costs will decline by less than 5 percent over the study period. Our uncertainty analysis attempted to account for wide variations in capacity factor depending upon the availability of hydro resource and the quality of the sizing and design process.

**Table 2.11: Micro- and Pico-hydroelectric Power Plant Design Assumptions**

Capacity	300 W	1 kW	100 kW
Capacity Factor (%)	30	30	30
Source	River	River	River
Life Span (year)	5	15	30
Gross Generated Electricity (kWh/year)	788	2,628	26,2800

### Mini-hydroelectric Power Systems

Mini-hydroelectric power schemes are “RoR” schemes using the same design principles and civil and electro-mechanical components as micro-hydro schemes. Mini-hydro technology is well established around the world and has found favor with private investors. The systems are simple enough to be built locally at low cost and have simple O&M requirements, which gives rise to better long-term reliability. These systems provide a source of cheap, independent and continuous power, without degrading the environment. Our economic assessment envisions a larger (5 MW) mini-hydro project developed for a large mini-grid or grid-connected application, as shown in Table 2.12. A properly-sited, well-designed mini-hydro project should have a capacity factor of 45 percent on an average.<sup>12</sup>

**Table 2.12: Mini-hydroelectric Power Plant Design Assumptions**

Capacity	5 MW
Capacity Factor (%)	45
Source	River
Life Span (year)	30
Gross Generated Electricity (GWh/year)	19.71

The capital cost of mini-hydro projects is very site-specific and can range between US\$1,400/kW and US\$2,200/kW. The probable capital cost is US\$1,800/kW. The equipment cost for mini-hydroelectric schemes has not changed over the past five years; therefore, we project only modest equipment cost declines over the study period.

<sup>12</sup> Based on several sources: (i) inputs from Alternate Hydro Energy Centre (AHEC), Roorkee; (ii) small hydro power (SHP): China's Practice – Prof Tong Jiandong, Director General, International Network for Small Hydro Power (IN-SHP); and (iii) Blue AGE Report, 2004 – A strategic study for the development of Small Hydro Power in the European Union, published by European Small Hydro Association (ESHA).

### Large Hydroelectric and Pumped Storage Power Systems

Unlike mini-, micro- and pico-hydro schemes, large hydroelectric projects typically include dams and water catchments in order to ensure a very high capacity factor consistent with the high construction cost of these facilities. The distinguishing characteristic of large hydroelectric and large pumped storage projects is the dam design, which is highly site-specific and can be of four general categories – gravity, concrete, earth or other fill and arch concrete. The water intake system determines the amount of pressure head and how water flows to the turbines. Dams with hydroelectric turbines located at the dam site obtain their head from the surface level of the reservoir. The hydroelectric power plants are installed directly under the dam, which allows effective use of water and no need for a feed channel. A conduit water intake system introduces the flow to the hydroelectric turbine via a feed channel and penstock (Figure 2.11).

**Figure 2.11: Conduit-type Intake Arrangement for Large Hydroelectric Power Plant**

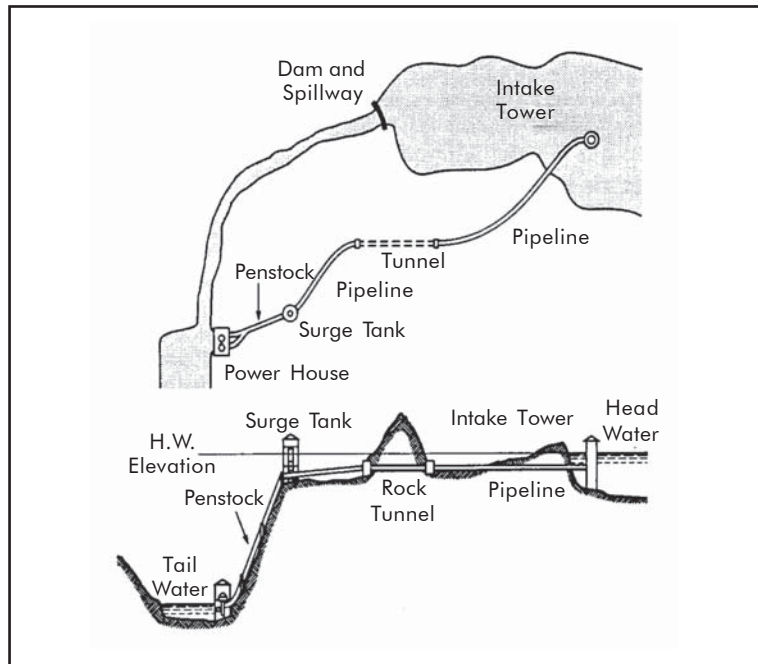

A pumped storage power generation scheme is a specialized scheme in which several power plants are used to optimize the power output in accordance with diurnal variation in system, load. In this scheme the hydroelectric power plant acts both as a generator and a pump, allowing water in a lower reservoir to be pumped up to upper reservoir during the low-load overnight period, and then generating electricity during peak load periods (Figure 2.12).

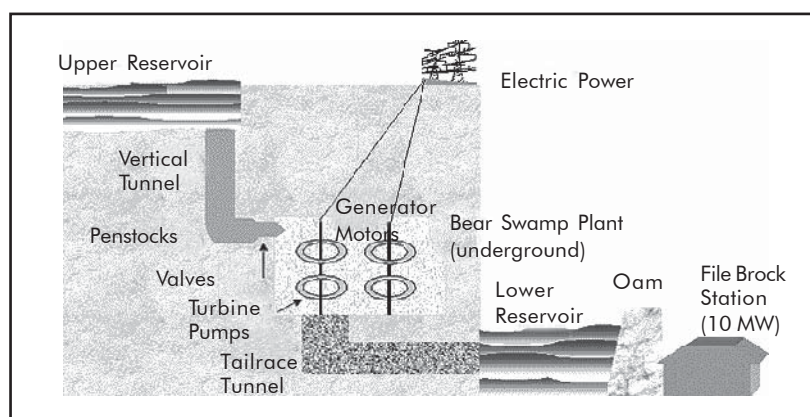

**Figure 2.12: Pumped Storage Hydroelectric Power Arrangement**

We assess two cases – a 100 MW conventional hydroelectric facility and a 150 MW-pumped storage hydroelectric facility. Design characteristics and performance parameters for the two cases are shown in Table 2.13.

**Table 2.13: Large Hydroelectric Power Design Assumptions**

	<i>Large Hydroelectric</i>	<i>Pumped Storage Hydroelectric</i>
Capacity	100 MW	150 MW
Capacity Factor (%)	50	10
Turbine-type	Francis	Francis Reversible Pump-turbine
Generation System	Pondage	Pumped Storage
Life Span (year)	40	40

There can be significant environmental and socioeconomic impacts associated with construction and operation of large hydroelectric power systems, which our assessment does not try and capture. It is imperative to investigate, predict and evaluate the potential environmental and other impacts, and to take sufficient safeguard measures to prevent them or incorporate the costs into the economic assessment process. Potential environmental and social impacts including sediment transport and erosion, relocation of populations, impact on rare and endangered species, loss of livelihood and passage of migratory fish species in hydro power plants.<sup>13</sup>

<sup>13</sup> References for the World Bank environmental assessment and social safeguard guidelines include: [http://web.worldbank.org/WBSITE/EXTERNAL/TOPICS/ENVIRONMENT/EXTENVASS\\_0,,menuPK:407994~pagePK:149018~piPK:149093~theSitePK:407988,00.html](http://web.worldbank.org/WBSITE/EXTERNAL/TOPICS/ENVIRONMENT/EXTENVASS_0,,menuPK:407994~pagePK:149018~piPK:149093~theSitePK:407988,00.html) and [http://web.worldbank.org/WBSITE/EXTERNAL/PROJECTS/EXTPOLICIES/EXTSAFEPOL\\_0,,menuPK:584441~pagePK:64168427~piPK:64168435~theSitePK:584435,00.html](http://web.worldbank.org/WBSITE/EXTERNAL/PROJECTS/EXTPOLICIES/EXTSAFEPOL_0,,menuPK:584441~pagePK:64168427~piPK:64168435~theSitePK:584435,00.html).

## Conventional Power Generation Systems

This section summarizes conventional power generation systems of all sizes, including distributed generation technologies such as diesel/gasoline engines and utility-scale power plants including oil and gas-fired combustion turbines (CTs), steam and combined cycle power plants and coal-fired electric technologies.

### Diesel/Gasoline Engine-generator Power Systems

Diesel and gasoline engines can accommodate power generation needs over a wide range, from several hundred W to 20 MW. Features including low initial cost, modularity, ease of installation and reliability have led to their extensive use in both developed and developing countries. A typical configuration is an engine/generator set, where the shaft output of a gasoline or diesel engine drives an electrical generator, usually via a clutch or similar mechanism. Gasoline engine generator sets are portable and easy to install and operate, but are relatively expensive to operate. A diesel generator has a higher efficiency (35-45 percent), and can use a range of fuels including light oil, residual oil and, even, palm or coconut oil. Diesel engines also have a wide capacity range, from 2 kW to 20 MW. A line diagram for a typical diesel generator is shown in Figure 2.13.

**Figure 2.13: Diesel-electric Power Generation Scheme**

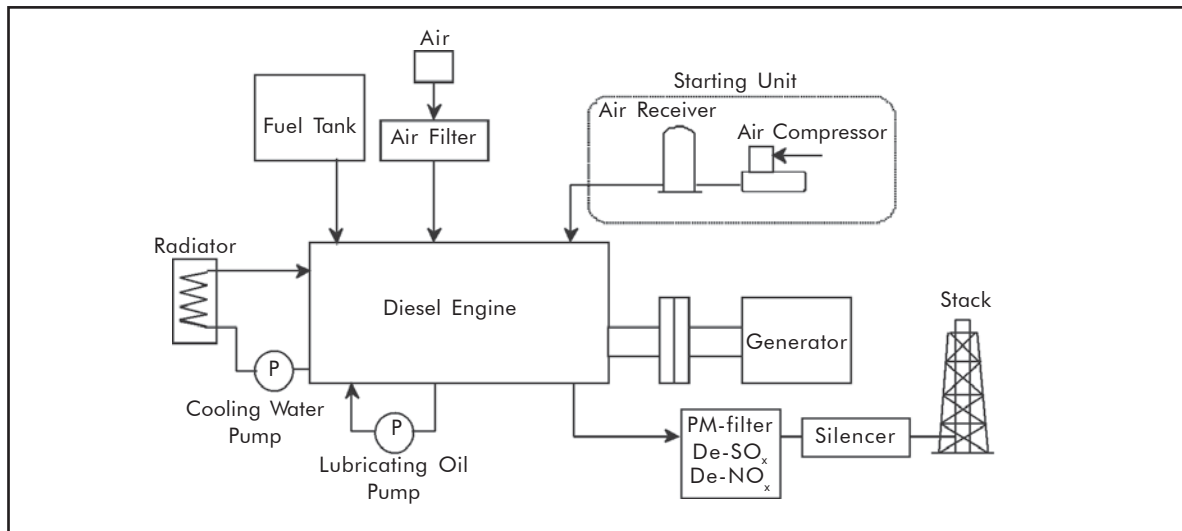

We have chosen four generic gasoline/diesel engine-generator arrangements in order to assess their economic effectiveness across a range of power supply configurations: (i) a 300 W and a 1 kW gasoline engine-generator configured for off-grid use; (ii) a 100 kW diesel engine configured for mini-grid use; and (iii) a 5 MW diesel engine generator

configured for grid connection. The type of engine and fuel reflect the commonly available commercial products. The design and operating parameters for each case are shown in Table 2.14.

**Table 2.14: Gasoline and Diesel Engine-generator Design Assumptions**

	300 W (off-grid)	1 kW (off-grid)	100 kW (mini-grid)	5 MW (grid)
Capacity Factor (%)	30	30	80	80/10
Engine-type	Gasoline	Gasoline	Diesel	Diesel
Fuel-type	Gasoline	Gasoline	Light Oil	Residual Oil
Thermal Efficiency (Gross, LHV, %)	13	16	38	43
Life Span (year)	10	10	20	20
Generated Electricity (GWh/year)	0.0008	0.003	0.7	35.0/4.4

Diesel engines have significant air emissions and require emissions control equipment (Table 2.15). These costs are included in the diesel generator economic assessment.

**Table 2.15: Emission Characteristics of Diesel Generators**

<i>Emission Standard</i>		<i>Gasoline Engine</i>		<i>Diesel Engine</i>	
		300 W	1 kW	100 kW	5 MW
PM	50mg/Nm <sup>3</sup>	Zero	Zero	80-120	100-200
SO <sub>x</sub>	2000mg/Nm <sup>3</sup> (<500MW:0.2tpd/MW)	Very Small	Very Small	1,800-2,000	4,400-4,700
NO <sub>x</sub>	Oil: 460	1,000-1,400 <sup>14</sup>		1,600-2,000	
CO <sub>2</sub>	g-CO <sub>2</sub> /net-kWh	1,500-1,900		650	

### Combustion Turbine Power Systems

Oil and Gas Combustion Turbines (CT) and Combined Cycle Gas Turbine (CCGT) power plants are considered together, as both utilize gas turbines burning natural gas or

<sup>14</sup> Smallest gasoline engines emit NO<sub>x</sub> beyond the World Bank's standard; however, it is not realistic to add removal equipment to these small generators. Thus, this cost is not included.



cost reductions for these technologies due to mass production and technological development; the economic assessment assumes that capital cost decrease 7 percent from 2004 to 2015.

**Coal-steam Electric Power Systems**

Coal-steam electric power plants typically have a pulverized coal (PC) boiler where coal is combusted, creating steam which passes through a turbine to generate electricity (Figure 2.15).

**Figure 2.15: Coal-fired Steam-electric Power Plant**

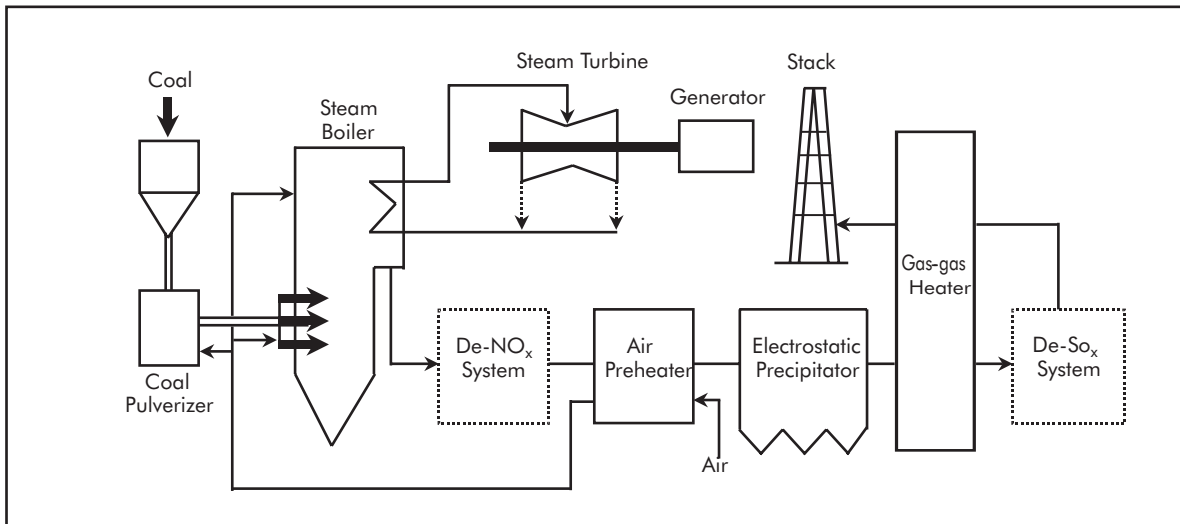

Table 2.17 shows design parameters and operating characteristics for a typical steam-electric power plant. We assume a 300 MW base-loaded plant with a SubCritical boiler.

**Table 2.17: Coal-fired Steam-electric Power Plant Design Assumptions**

Capacity	300 MW		500 MW	
Boiler-type	PC SubCritical	PC SubCritical	PC SuperCritical	PC UltraSuperCritical
Thermal Efficiency (gross, LHV, %)	41	42	44	47
Capacity Factor (%)			80	
Life Span (year)			30	

Thermal performance has been increased mainly by the adoption of progressively higher steam conditions and there are currently more than 600 SuperCritical (SC) boilers in operation worldwide. Although pressures have increased well into the SC range, design steam temperatures of subcritical plants have normally been set at 540°C (1,005°F). This level is chosen to minimize the use of high chrome (austenitic) steels, particularly for high-temperature section components. The adoption of new high strength ferritic steels has recently enabled the steam conditions to be raised above 25 MPa, 566°C (1,050°F), with the current maximum boiler outlet steam temperature being about 593°C (1,100°F) to 600°C (so-called “UltraSuperCritical [USC]” conditions). Further development of advanced materials is the key to even higher steam conditions and major development projects are in progress, particularly in Denmark, Germany, Japan and the United States. Plants with main steam conditions of up to 35 MPa and up to 650°C (1,200°F) are foreseen in a decade, giving an efficiency approaching 50 percent.

### Oil-fired Steam-electric Power Systems

Oil-fired steam-electric power plants were in common use until the oil price shocks of the 70s. High oil costs and availability of newer, more efficient technologies has resulted in less use of this technology. An oil-fired steam-electric power plant schematic is shown in Figure 2.16. In this system, the heat generated in the oil-fired boiler is turned into steam and it generates electricity using a steam turbine.

**Figure 2.16: Oil-fired Steam-electric Power Plant**

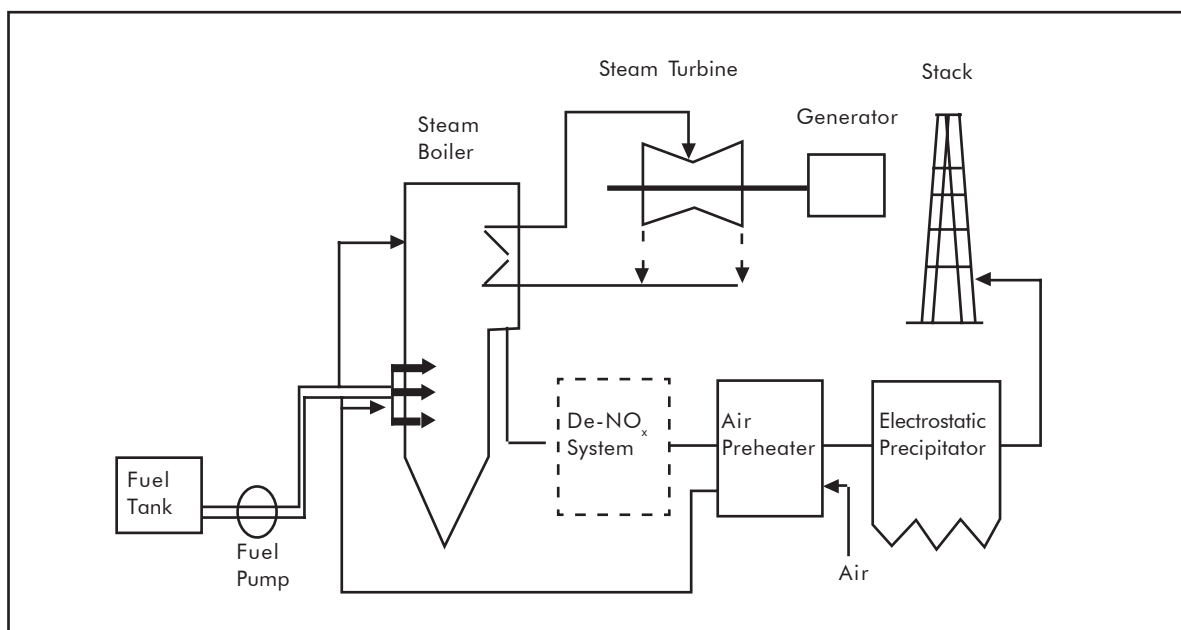

For the economic assessment, we chose a large, grid-connected base-load unit (300 MW), with operating characteristics as shown in Table 2.18.

**Table 2.18: Oil-fired Steam-electric Power Plant Design Assumptions**

Capacity	300 MW
Capacity Factor (%)	80
Fuel-type	Residual Oil
Thermal Efficiency (gross, LHV, %)	41
Life Span (year)	30

An oil-fired power plant sited in India burning residual fuel oil will emit significant sufficient particulate matter (PM) to require an ESP but will not require any sulfur oxides (SO<sub>x</sub>) or NO<sub>x</sub> controls (Table 2.19).

This is a very mature technology and no appreciable cost reductions or performance improvements are expected.

**Table 2.19: Emissions from Oil-fired Steam-electric Power Plants**

	Emission Standard for Oil	Boiler Exhaust	Result Stack Exhaust	Reduction Equipment
SO <sub>x</sub>	2,000 mg/Nm <sup>3</sup> (<500 MW:0.2tpd/MW)	1,000 mg/Nm <sup>3</sup> (20 tpd)	←	Not Required
NO <sub>x</sub>	460 mg/Nm <sup>3</sup>	200 mg/Nm <sup>3</sup>	←	Not Required
PM	50 mg/Nm <sup>3</sup>	300 mg/Nm <sup>3</sup>	50 mg/Nm <sup>3</sup>	Required
CO <sub>2</sub>	–	670 g-CO <sub>2</sub> /kWh	←	–

Note: “–” means no cost needed.

## Emerging Power Generation Technologies

We also review and assess four promising new power generation technologies – coal integrated gasification combine cycle (IGCC), coal atmospheric fluidized bed combustion (AFBC), microturbines and fuel cells. The first two technologies have considerable potential for large grid-connected applications, while the latter two have considerable modularity which may make them attractive in mini-grid applications.

### Coal IGCC Power Systems

An IGCC power plant gasifies coal to produce a synthesis gas which can be fired in a gas turbine. The hot exhaust from the gas turbine passes through a heat recovery steam generator (HRSG) where it produces steam that drives a turbine. Power is produced from both the gas and steam turbine generators. By removing the emission-forming constituents from the synthetic gas, an IGCC power plant can meet extremely stringent emission standards. Figure 2.17 shows a typical configuration for a coal-fired IGCC power plant as considered in this study. Table 2.20 provides the design parameters and operating characteristics assumed for the 300 MW coal-fired IGCC power plant assessed here.

IGCC power plants are capable of removing 99 percent of Sulfur (S) in the fuel as elemental S; hence the S emissions are extremely low. The high pressure and low temperature of combustion also drastically mitigates NO<sub>x</sub> formation. IGCC technology is very new, thus the cost of these plants will not decrease significantly over the term of this study.

**Figure 2.17: Coal-fired IGCC Power Plant Arrangements**

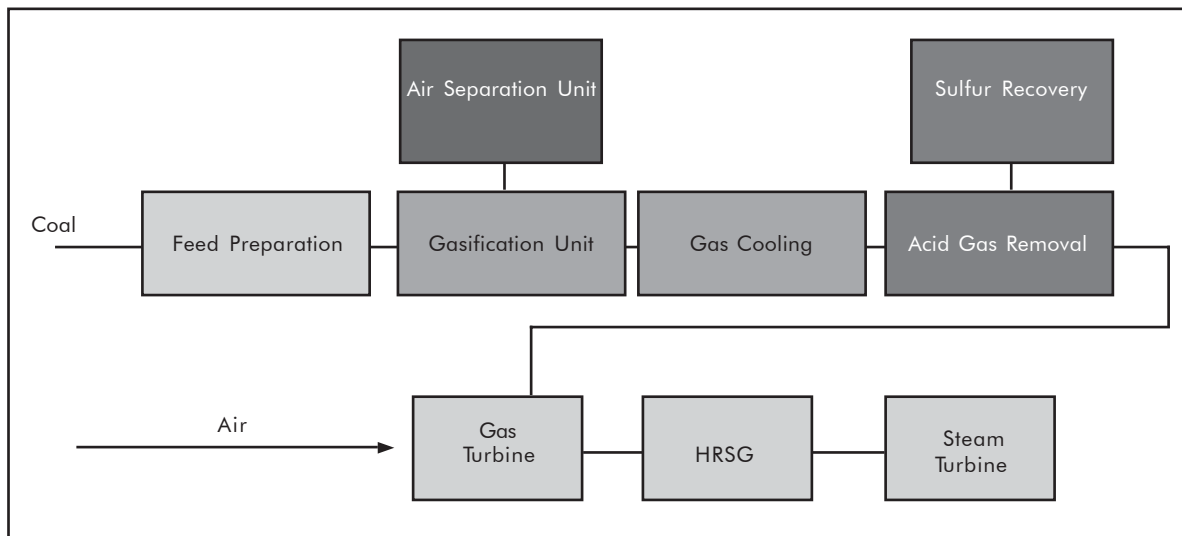

**Table 2.20: Coal-fired IGCC Power Plant Design Assumptions**

Capacity	300 MW	500 MW
Efficiency (gross, LHV, %)	47	48
Capacity Factor (%)	80	
Life Span (year)	30	



## Coal-fired AFBC Power Systems

In AFBC, limestone is injected into the combustion zone to capture the S in the coal. The calcium sulfate ( $\text{CaSO}_4$ ) by-product (formed from the combination of  $\text{SO}_2$  and the CaO in the limestone) is captured and can be easily disposed along with the fly ash from combustion (Figure 2.18). AFBC boilers are similar in design and operation to conventional PC boilers and utilize the same Rankine steam cycle. AFBC boilers can efficiently burn low reactivity, low-grade and high-ash fuels, which may not be burned in conventional PCs. For the economic assessment of coal-fired AFBC systems, we assumed a large, base-loaded power plant of 300 MW utilizing a subcritical steam cycle. Table 2.21 compare the emission results for this AFBC design with the World Bank emission standard.

**Table 2.21: Emission Results for a Coal-fired AFBC Power Plant**

	<i>The World Bank Emission Standard for Coal</i>	<i>Emissions Calculated for a Coal-fired AFBC Design Located in India</i>
$\text{SO}_x$	2000 mg/Nm <sup>3</sup> (<500MW: 0.2 tpd/MW)	940 mg/Nm <sup>3</sup> <sup>15</sup>
$\text{NO}_x$	750 mg/Nm <sup>3</sup>	250 mg/Nm <sup>3</sup> <sup>16</sup>
PM	50 mg/Nm <sup>3</sup>	Under 50 mg/Nm <sup>3</sup> <sup>17</sup>

AFBC technology is expected to be used widely in the future, mainly in new power plant applications. Costs are expected to decline, especially in developing countries such as China and India.

## Microturbine Power Systems

Microturbines are small, very efficient Brayton cycle turbine engines that can run on a range of fuels including natural gas, gasoline, diesel or alcohol. Microturbines are very high-speed devices (up to 120,000 revolutions per minute [RPM]) with quick starting capability, low noise, low  $\text{NO}_x$  emissions and the flexibility to be configured as combined heat and

<sup>15</sup> Many solid fuels such as Indian coal contain CaO in the ash and are capable of capturing  $\text{SO}_2$  without the addition of limestone. If the S in the coal is relatively low and/or the environmental standards are not very strict, limestone may not be required.

<sup>16</sup> Lower than 100 mg/Nm<sup>3</sup> (typically 30-50 mg/Nm<sup>3</sup>) is possible with the addition of SNCR (selective noncatalytic reduction) system in the AFBC boiler.

<sup>17</sup> This depends on the design of the ESP or fabric filter; in some developing countries higher particulates (for example, 100 or 150 mg/Nm<sup>3</sup>) may be allowed. In this case, the capital costs may be slightly lower (for example, US\$10-15/kW).

**Figure 2.18: Coal-fired AFBC Boiler Schematic**

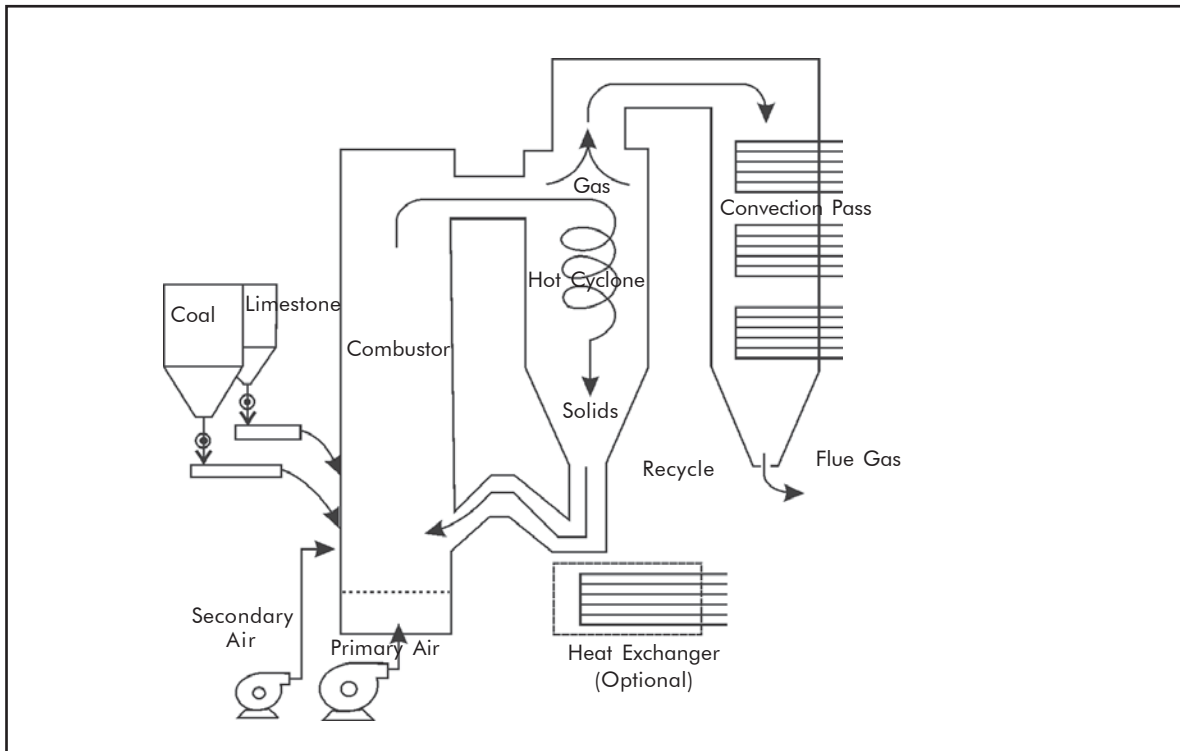

Source: The World Bank.<sup>18</sup>

power (CHP) devices with overall thermal efficiencies approaching 60 percent. The basic layout of a micro-turbine is identical to that of a larger scale simple cycle or closed cycle gas turbine plant (Figure 2.19).

**Figure 2.19: Gas-fired Microturbine Schematic**

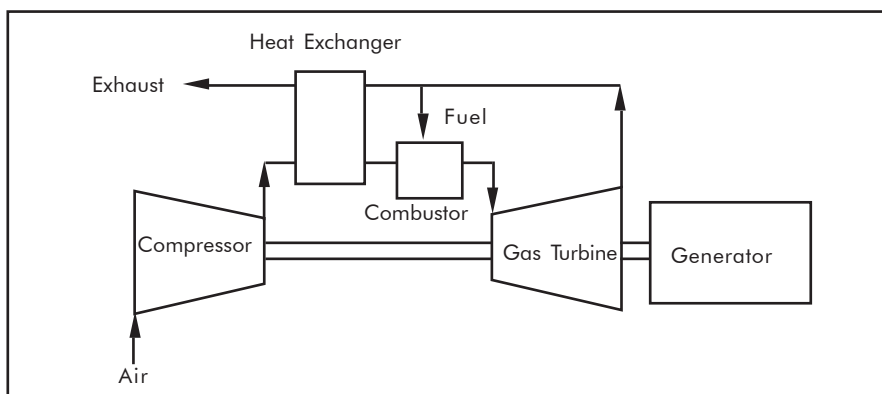

<sup>18</sup> "The Current State of Atmospheric Fluidized-bed Combustion Technology," Washington, DC: The World Bank, Technical Paper # 107, Fall 1989.

For the economic assessment, we focus on a larger microturbine with operating characteristics as shown in Table 2.22 and configured for electricity production in a mini-grid.

The environmental impacts of microturbines are extremely low and no emission control equipment is required. This technology is rapidly evolving and the two leading manufacturers (Elliot and Capstone) are promising a 50 percent reduction in capital costs (from US\$1,500/kW to US\$500/kW) within 20 years. Our assessment assumes a 4 percent annual capital cost reduction over the study period.

**Table 2.22: Gas-fired Microturbine Design Assumptions**

Capacity	150 kW
Capacity Factor (%)	80
Fuel-type	Natural Gas
Thermal Efficiency (LHV, %)	30
Life Span (year)	20

### Fuel Cell Power Systems

Fuel cells operate through an electrochemical process in which H and air pass through a reactor, producing power and harmless by-products (Figure 2.20). This technology is in the early stages of commercialization (some 200 devices have been installed to date) and there are several competing cell designs including polymer electrolyte fuel cell (PEFC), phosphoric acid fuel cell (PAFC), molten carbonate fuel cell (MCFC) and solid oxide fuel cell (SOFC). Fuel cells can be configured to suit the load requirements and installations of 200 kW to 11 MW are in service. The MCFC design, rated at 300 kW, is considered ready for commercialization.

We will assess two fuel cell configurations (Table 2.23), one for mini-grid applications and one for small grid-connected applications.

**Figure 2.20: Operation of a Fuel Cell**

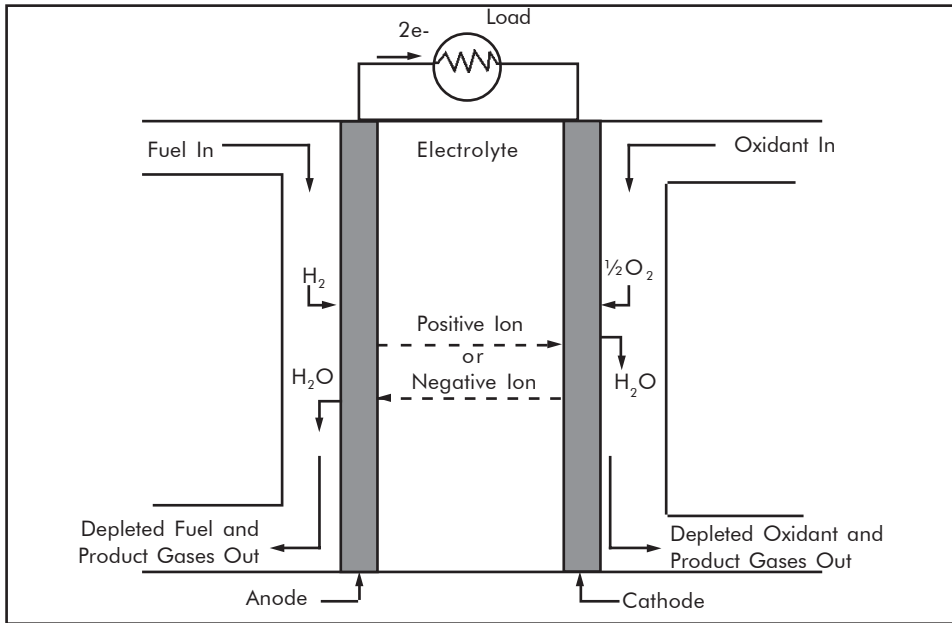

Source: U.S. DOE Office of Fossil Energy NETL, 2000.

**Table 2.23: Fuel Cell Power System Design Assumptions**

	200 kW Fuel Cell	5 MW Fuel Cell
Capacity	200 kW	5 MW
Capacity Factor (%)	80	80
Fuel-type	Natural Gas	Natural Gas
Electrical Efficiency (LHV, %) <sup>19</sup>	50	50
Life Span (year)	20	20

Fuel cells have essentially negligible air emission characteristics, although they do produce CO<sub>2</sub> in approximately the same amounts as a gas-fired power plant. Fuel cell manufacturers expect significant performance improvements and capital cost reductions as this new technology is commercialized. Our economic assessment assumes reductions of 20 percent by 2010 and 40 percent by 2015.

<sup>19</sup> Operating fuel cells as a combined heat and power (CHP) plant can increase fuel cell plant efficiency to 70 percent.

# 3. Technical and Economic Assessment of Power Delivery

Unless located in an off-grid or premise-scale application, power generation technologies are deployed as part of an integrated electricity grid or an electrically-isolated mini-grid. The grid serves to transport the electric power from the generator to the customer via high-voltage, long-distance transmission and low-voltage distribution networks. This Chapter briefly describes the requirements for transmitting and distributing electricity production to end users, and discusses grid integration issues associated with certain renewable power generation technologies.

Power delivery requirements and associated costs derive entirely from the specific power system configuration. Table 3.1 summarizes the power delivery requirements and indicative associated levelized costs, inclusive of capital costs, O&M costs and technical losses, for the four power generation configurations considered in this study. The balance of this section provides more detail on the technical and economic characteristics of power delivery.

**Table 3.1: Power Delivery Requirements According to Generation Configuration**

	<i>Grid-connected</i>			
	<i>Large</i>	<i>Small</i>	<i>Mini-grid</i>	<i>Off-grid</i>
Typical Generator Size (kW)	50-300 MW	5-50 MW	5 kW-250 kW	0.3-5.0 kW
Annual Output	1,000 GWh	35 GWh	1 GWh	0.005 GWh
Transmission Costs	~US¢0.25/kWh (100 km circuit)	~US¢0.5/kWh (20 km circuit)	None	None
Distribution Costs	None	None	~US¢1-7/kWh	None

## Transmission and Distribution Facilities

Nominal distribution voltages vary between 100 and 1,000 V for secondary distribution (sometimes called reticulation) and between 10 kV to 35 kV for primary distribution.<sup>20</sup> Most distribution networks limit voltages to no more than 35 kV for safety reasons. Installation standards, materials and components differ between each country, but every distribution system comprises three basic elements – poles, wires and transformers.

Nominal transmission voltages are between 35 kV and 230 kV; typical voltages used in developing countries include 66/69 kV, 110/115 kV and 220/230 kV (Table 3.2).

**Table 3.2: Transmission Voltages in Developing Countries**

	<i>Countries</i>	<i>Typical Voltages</i>
Africa	Algeria	220, 150, 90, 60
	Malawi	132, 66
	Senegal	225, 90, 30
	Tanzania	220, 132, 66
	Tunisia	225, 150, 90
Asia	Cambodia	230, 115
	India	220, 230, 132, 110, 33
	Lao PDR	230, 115, 35, 22
	Mongolia	220, 110, 35
	Myanmar	230, 132, 66
	Philippines	230, 138, 115, 69
	Vietnam	220, 110

As with the distribution network, transmission facilities mainly comprise wires, poles or steel towers, and transformers, albeit all at larger sizes to accommodate larger power flow and higher voltages.

<sup>20</sup> See IEC 60038.

## Operations and Maintenance Requirements

Transmission and distribution (T&D) equipment must be regularly maintained to operate in the manner intended and with the life span promised by the manufacturer. T&D equipment may also require repair of damage caused by storms or accidents (for example, vehicles hitting power poles). A good rule of thumb is that O&M costs for a power delivery system should run between 1/8 and 1/30 of capital cost on an annual basis.<sup>21</sup> The lifetime of a grid is considered to be around 20-30 years for depreciation purposes, but can be more than 50 years with proper maintenance.<sup>22</sup>

## Power Delivery Losses

Losses in electric power output from generator to customer can vary from 10 percent in a well-designed and maintained power grid to 25 percent or more (Table 3.3). As a

**Table 3.3: Power Delivery Loss Rates in Selected Countries**

Country or Region	T&D Loss (%)	Fiscal Year	Source
Cambodia	22.6	1998	EDC
Chubu Region (Japan)	4.9	2003	CEPCO Annual Report
India	31.42	1999	Indian Power Planning Committee Annual Report (2001/2002)
Karnataka State (India)	31.69	2002-03	KPTCL Data <a href="http://www.kerc.org/english/index.html">http://www.kerc.org/english/index.html</a>
Kenya	16.2	1997	Overseas Japan Electric Power Investigation Committee (2000)
Lao PDR	24	2000	Overseas Japan Electric Power Investigation Committee (2000)
Malawi	14.8	1999	ESCOM Annual Report (1999/2000)
Philippines	14.4	2001	NPC Annual Report MERALCO Annual Report
Tanzania	11.9	1996	ESKOM Statistical Yearbook
Tunisia	11.2	1998	STEG
Vietnam	14.5	2000	Fifth Electric Power Master Plan (EVN)
Zimbabwe	10.8	1997	Annual Report
<b>Average</b>	<b>17.2</b>	–	–

Note: “–” means no cost needed.

<sup>21</sup> *Distributed Power Generation*, Willis, H.L., and Scott, W.G.

<sup>22</sup> This, of course, will vary by equipment-type and construction and the operating conditions, including temperature, humidity, exposure to corrosives, etc.

general rule, distribution losses account for more than two-third of the total power delivery losses. Losses are higher at the distribution level because resistance losses in conductors are proportional to the square of the electric current  $I^2A$ . Since lower distribution voltages translate into higher current flows, the distribution system is inherently less efficient.

## **Economic Assessment of Power Delivery**

A detailed formulation of the cost equations is provided in the CD-ROM (see Annex 2) to this report. Here we provide an overview of the approach and summary results. We assume overhead line construction, reflecting rural electrification practice in developing economies, and use of international (IEC) standards for component choice and construction. We assume there are no environmental or social impacts of power transmission and delivery. As T&D technology is very mature, we do not project any cost reductions or performance improvements over the term of the assessment.

As with the calculation of generation costs, we convert the capital costs of T&D facilities into a levelized cost (US\$/kWh) over the life span of the equipment and the volume of power delivered. Transmission costs and distribution costs can then be expressed simply as the sum of their respective levelized capital cost plus O&M costs plus the cost of losses.

### **Distribution Costs**

The capital cost of distribution facilities is proportional to both the circuit-kilometer of distribution conductor and the rated output of the generation source. Only a low-voltage distribution network is needed when the power station output is 60 kW or less, as loss reductions will be nominal unless the distribution circuit kilometers are very large. A power station output of 100 kW may require a higher voltage network with transformers, depending on factors such as customer density and size of the mini-grid. The capital cost formulation used here is shown in Figure 3.1.

A distribution capital cost calculation was performed for each power generation technology configured to serve a mini-grid. Actual installed distribution costs typical of Indian rural electrification programs were used (US\$5,000 per circuit km for medium voltage (33 kV) and US\$3,500/circuit-km for low-voltage reticulation (0.2 kV), along with US\$3,500 per

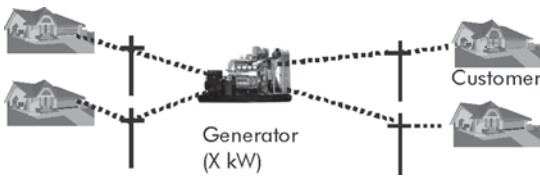
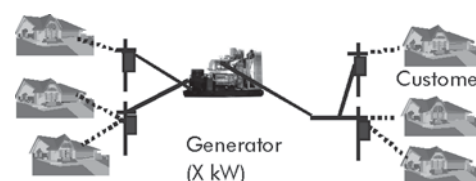

**Figure 3.1: Calculation Model for Distribution Costs**

<p><b>Rated Output: X (kW)</b></p>  <p><math>X \leq 60</math> kW (No High-voltage Line)</p>	<p><b>Image and Length of Distribution Line</b> (High-voltage Line:—, Low-voltage Line:·····, Transformer: ▣)</p>  <p>The Length of Low-voltage Line (km) = 0.0142 X</p>		
	The Length of Low-voltage Line (km)		
25 kW	0.36		
60 kW	0.85		
<p><math>60 \text{ kW} &lt; X</math> (With High-voltage Line)</p>	 <p>The Length of High-voltage Line (km) = 0.01 X</p> <p>The Length of Low-voltage Line (km) = 0.0142 X</p> <p>The Number of 3φ50 kVA Transformer (unit) = X/50</p>		
	The Length of Line (km)		The Number of 3φ50 kVA Transformer (unit)
	High-voltage Line	Low-voltage Line	
100 kW	1.0	1.4	2
150 kW	1.5	2.1	3
200 kW	2.0	2.8	4
1 MW	10	14	20

MV/LV transformer).<sup>23</sup> O&M cost is calculated as 2 percent of the capital cost annually and losses are handled by decrementing the net delivered electricity by 12 percent.<sup>24</sup>

The levelized costs of distribution for each power generation technology assessed in a mini-grid configuration are shown in Table 3.4.

**Table 3.4: Power Delivery Costs Associated with Mini-grid Configurations**

Generating-types	Rated Output	CF (%)	US¢/kWh		Mini-grid			
			2005	2010	2015	2005	2010	2015
Solar-PV	25 kW	20	7.42	6.71	6.14	56	56	56
Wind	100 kW	25	3.80	3.61	3.49	193	193	193
PV-wind Hybrids	100 kW	30	5.09	4.72	4.42	193	193	193
Geothermal	200 kW	70	2.53	2.38	2.34	193	193	193
Biomass Gasifier	100 kW	80	1.58	1.51	1.48	193	193	193
Biogas	60 kW	80	1.03	0.99	0.99	56	56	56
Microhydro	100 kW	30	2.43	2.36	2.36	193	193	193
Diesel/Gasoline	100 kW	80	3.08	2.94	2.97	193	193	193
Microturbines	150 kW	80	4.69	4.54	4.54	193	193	193
Fuel Cells	200 kW	80	3.99	3.72	3.58	193	193	193

Table 3.4 suggests there is a separate and distinct “cost” associated with power delivery in mini-grids that, if added to generation costs, would be a significant component of overall cost of electricity. Because the fixed and variable cost of delivery is spread across electricity production, power generation technologies with low capacity factors have a higher net delivery cost burden per kWh. The proper application of these mini-grid delivery costs will depend on the planning context faced by the power system planner. If the mini-grid is

<sup>23</sup> Interviews to Electric Power Companies in India, November 2004, Mahesh Vipradas, TERI in India.

<sup>24</sup> Distribution Loss Percentage = Average T&D Loss Percentage x Distribution Loss Rate = 17.2% x 0.7 = 12%.

being considered as an alternative to grid connection, then the system planner might want to consider these extra costs. If the mini-grid will eventually be connected to the larger grid, including the mini-grid generation sources, there might not be any reason to make such a distinction. The decision whether to include these costs in evaluating an electrification alternative is left to the practitioner. We do not include these power delivery costs in the comparisons of different generating costs by generation technology and configuration.

### Transmission Costs

A large power station requires construction of transmission lines from the power station to the load. As transmission costs are driven by the distance from the power station to the load center, this is a convenient parameter for estimating transmission costs (Figure 3.2).

**Figure 3.2: Calculation Model for Transmission Costs**

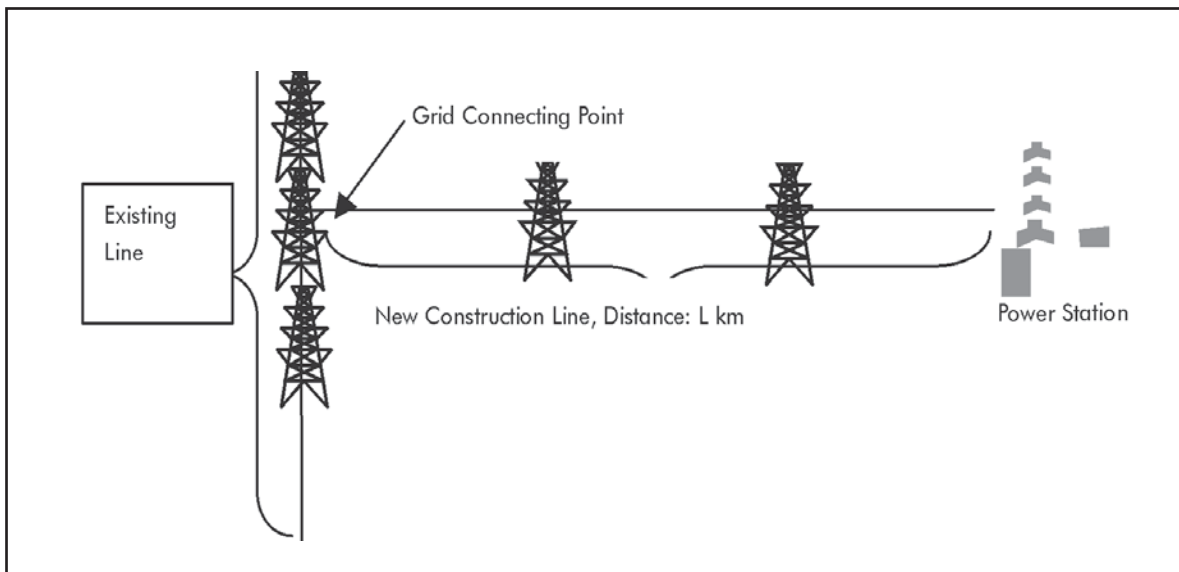

We assume representative voltage level and line-types relative to power station rated output as shown in Table 3.5. As with the distribution cost calculation, capital and O&M costs can be expressed on a per-circuit-kilometer annualized basis by levelizing the capital cost and assuming annual O&M costs are a fixed fraction of capital costs. Transmission losses are incorporated by decrementing the net power delivery in accordance with the circuit km associated with each power generation configuration.

**Table 3.5: Assigning Transmission Line Costs According to Power Station Output**

Rated Output Power Station (MW)	Representative Voltage Level (kV)	Line-type	Capital Cost per km (US\$/km)
5	69	DRAKE 1cct	28,177
10	69	DRAKE 1cct	28,177
20	69	DRAKE 1cct	28,177
30	138	DRAKE 1cct	43,687
100	138	DRAKE 2cct	78,036
150	230	DRAKE 2cct	108,205
300	230	DRAKE (2) 2cct	151,956

Source: Chubu Electric Power Company Transmission Planning Guidelines.

Using these associated transmission facilities, we can calculate the capital and levelized delivery costs associated with transmission for each grid-connected power generation technology, as shown in Table 3.6.

**Table 3.6: Power Delivery Costs Associated with Transmission Facilities**

Generating-types	Rated Output (MW)	CF (%)	(US¢ x 10 <sup>-2</sup> ) / (kWh-km)			US\$/ (kW-km)		
			2005	2010	2015	2005	2010	2015
Solar-PV	5	20	4.80	4.75	4.71	5.64	5.64	5.64
Wind	10	30	1.60	1.58	1.57	2.82	2.82	2.82
Wind	100	30	0.54	0.53	0.52	0.78	0.78	0.78
Solar Thermal Without Thermal Storage	30	20	0.64	0.62	0.61	1.46	1.46	1.46
Geothermal	50	90	0.25	0.25	0.25	0.87	0.87	0.87
Biomass Gasifier	20	80	0.54	0.53	0.52	1.41	1.41	1.41
Biomass Steam	50	80	0.31	0.30	0.30	0.87	0.87	0.87
MSW/Landfill Gas	5	80	1.16	1.16	1.16	5.64	5.64	5.64
Mini-hydro	5	45	2.02	2.02	2.02	5.64	5.64	5.64
Large-hydro	100	50	0.37	0.37	0.37	0.78	0.78	0.78
Pumped Storage Hydro (peak)	150	10	1.57	1.56	1.55	0.72	0.72	0.72

(continued...)

(...Table 3.6 continued)

Generating-types	Rated Output (MW)	CF (%)	(US¢ x 10 <sup>-2</sup> ) / (kWh-km)			US\$/ (kW-km)		
			2005	2010	2015	2005	2010	2015
Diesel/Gasoline Generator	5	80	1.19	1.18	1.18	5.64	5.64	5.64
Diesel/Gasoline Generator (peak)	5	10	8.98	8.97	8.97	5.64	5.64	5.64
Fuel Cells	5	80	1.24	1.22	1.21	5.64	5.64	5.64
Oil/Gas Combined Turbines (peak)	150	10	1.29	1.28	1.28	0.72	0.72	0.72
Oil/Gas Combined Cycle	300	80	0.17	0.16	0.16	0.51	0.51	0.51
Coal Steam	300	80	0.16	0.15	0.15	0.51	0.51	0.51
Coal AFB	300	80	0.15	0.15	0.15	0.51	0.51	0.51
Coal IGCC	300	80	0.17	0.16	0.16	0.51	0.51	0.51
Oil Steam	300	80	0.19	0.19	0.18	0.51	0.51	0.51

As we saw with power delivery costs associated with mini-grids, the levelized transmission costs for power generation technologies with low rated output and low capacity factor are quite high, as the high fixed costs of transmission are spread over lower annual electricity production. The calculation approach used here yields the cost of delivering the output of a given power generation technology per circuit-km. This can be converted to a basis similar to the distribution costs by specifying the physical configuration of the transmission network. However, once again we present these results for informational purposes and do not make a blanket recommendation for how they should be used in the planning process. As with distribution-related power delivery costs, we do not include these transmission-related power delivery costs in the comparisons of different generating costs by generation technology and configuration.

### Grid Integration Issues

Intermittent power sources connected to the power grid can cause frequency and voltage stability problems for the system operator. As more and more stochastic power sources such as wind turbines are being interconnected to power grids, this topic has become the subject of intensive study.<sup>25</sup>

<sup>25</sup> Wind Power Impacts on Electric Power System Operating Costs: Summary and Perspective on Work to Date, J. Charles Smith, UWIG, others.

As a general rule, all power systems must adopt counter-measures to maintain frequency and voltage stability in the event of unplanned outages of large generators, due to renewable resource variability or any other reason. The problem of wind power intermittency is exacerbated by the many induction generators in use, as the large inrush currents on cut-in have a hard-to-predict impact on voltage and frequency stability.

Mitigation measures for ensuring voltage stability are well known, and include procuring additional operating reserves, arranging for contingency resources and incorporating additional voltage control capability. Numerous studies have estimated the costs associated with accommodating wind power, as shown in Table 3.7.

**Table 3.7: Costs of Accommodating Wind Power Intermittency (US¢/kWh)**

<i>Study</i>	<i>Relative Wind Penetration (%)</i>	<i>Spinning Reserve</i>	<i>Load Following Operation</i>	<i>Unit Commitment</i>	<i>Total Capacity Factor</i>
UWIG/Xcel	3.5	0	0.041	0.144	0.185
PacifiCorp	20	0	0.25	0.3	0.550
BPA	7	0.019	0.028	0.1-0.18	0.147-0.227
Hirst	0.06-0.12	0.005-0.03	0.07-0.28	NA	NA
We Energies I	4	0.112	0.009	0.069	0.190
We Energies II	29	0.102	0.015	0.175	0.292
Great River I	4.3	–	–	–	0.319
Great River II	16.6	–	–	–	0.453
CA RPS Phase I	4	0.017	NA	NA	NA

Source: E.ON.

Note: NA = Not applicable; “–” means no cost needed.

## 4. Results and Discussion

This section presents the results of the economic assessment of power generation technologies in various grid configurations. The work undertaken was intended to identify, characterize and assess the technical, economic and commercial prospects for a broad spectrum of electricity generation and delivery technologies capable of serving rural, peri-urban and urban populations in developing countries. The study covered a total of 22 technologies, which, together, with applications, permutations and deployment configurations comprised 42 total cases. The technologies included both renewable and fossil fuel-based power generation technologies in configurations suitable for off-grid, mini-grid and small and large grid-connected operations.

Our objective in developing these economic assessments was to assist the power system planner or policy maker to make the right technology selection, given local conditions and available resources. The assessment results are necessarily generic, providing an indicative but not conclusive or specific comparison of relative generation capital cost and generating cost. Given the variability in RE resources and other technology performance parameters, these first-order calculations need to be refined using national or site-specific data to yield a conclusive comparison. Furthermore, the analysis does not consider the interactions and combinations of use of technologies within an overall power supply plan in order to provide electricity at the least cost by appropriate combination of peak, mid-peak and off-peak generation options.

There are several summary result Tables included in the following subsections. Section 4.1 presents the generation capital costs of 22 electric power generation technologies in US\$ per kW. Section 4.2 presents the corresponding levelized generating costs in US¢ per kWh. The economic assessment process generated similarly detailed data for capital costs and generating costs projected for 2010 and 2015, including estimated uncertainty bands. This information is provided technology-by-technology in the CD-ROM (see Annex 3) to this report.

## Power Generation Technology Configurations

Throughout the presentation of assessment results we retain generation capacity as a simple organizing principle. We distinguish four size ranges: Large grid-connected power generation, small grid-connected power generation, power generation in mini-grids and off-grid power generation.

Power generation technologies larger than 100 MW capacity are exclusively conventional power plants burning fossil fuels (coal, heavy oil or natural gas), or are large hydroelectric power plants. In developing countries, power plants of this magnitude are operated by central or state electricity boards or in some cases by investor-owned utility companies or by independent power operations. The units in this range are always grid-connected and serve urban or peri-urban areas with high-load density.

Power generation technologies in the 5-50 MW range can be either conventional power plants burning fossil fuels or renewable power plants using solar, wind, geothermal, hydro, biomass or biogas resources. The units in this range are usually grid-connected, but can also be operated in a mini- or distributed-grid configuration or in auto-production mode. These power generation technology types and sizes find wide application in grid-connected power applications serving rural and suburban areas, dedicated industrial or large commercial customers, and mini-grids serving rural or peri-urban areas. The option of combined heat and power plants are not considered in this evaluation.

Power generation technologies smaller than 5,000 kW are often configured for serving small stand-alone loads or noninterconnected mini-grids. These technologies frequently use RE sources including solar, wind, hydro, biomass or biogas, are often configured in hybrid arrangements with small, diesel engine-generators as a back-up supply, and are frequently found in mini-grid or off-grid applications and in developing countries.

Finally, it is possible to configure some power generation technologies down to the individual facility, household or business. This type of off-grid arrangement is possible with solar, wind, hydro, biomass and diesel power generation technologies of size less than 25 kW. However, such an arrangement would be a least-cost electrification solution only if mini-grid arrangements or grid connection were not economical prospects.

## Results: Power Generation Capital Costs

Table 4.1 and Table 4.2 provide detailed economic capital cost characterizations of each power generation technology configuration as of 2005, arranged according to use of RE vs. fossil fuels. This data is useful for the planner attempting to estimate capital cost requirements for various technologies and size ranges. As would be expected, the larger conventional power stations are much less expensive in initial cost terms than the renewable power technologies, although there are some exceptions. Biomass gasifiers, wind power and micro/mini hydro all have capital costs of less than US\$1,800/kW. Table 4.3 shows the range of 2005 and projected 2010 and 2015 capital costs for each generation technology.



**Table 4.1: 2005 Renewable Power Technology Capital Costs (US\$/kW)**

Technology	Life Years	Capacity Factor %	Rated Output kW	Engineering	Equipment & Materials	Civil	Erection	Process Contingency	Total
• Solar-PV	20	20	0.050	–	6,780	–	–	700	<b>7,480</b>
	20	20	0.300	–	6,780	–	–	700	<b>7,480</b>
	25	20	25	200	4,930	980	700	700	<b>7,510</b>
	25	20	5,000	200	4,640	980	560	680	<b>7,060</b>
• Wind	20	25	0.300	50	3,390	770	660	500	<b>5,370</b>
	20	25	100	50	2,050	260	160	260	<b>2,780</b>
	20	30	10,000	40	1,090	70	100	140	<b>1,440</b>
	20	30	100,000	40	940	60	80	120	<b>1,240</b>
• PV-wind-hybrid	20	25	0.300	30	4,930	460	390	630	<b>6,440</b>
	20	30	100	130	3,680	640	450	520	<b>5,420</b>
• Solar Thermal With Storage	30	50	30,000	920	1,920	400	1,150	460	<b>4,850</b>
Without Storage	30	20	30,000	550	890	200	600	240	<b>2,480</b>
• Geothermal Binary	20	70	200	450	4,350	750	1,670	–	<b>7,220</b>
Binary	30	90	20,000	310	1,560	200	2,030	–	<b>4,100</b>
Flash	30	90	50,000	180	955	125	1,250	–	<b>2,510</b>
• Biomass Gasifier	20	80	100	70	2,490	120	70	130	<b>2,880</b>
	20	80	20,000	40	1,740	100	50	100	<b>2,030</b>
• Biomass Steam	20	80	50,000	90	1,290	170	70	80	<b>1,700</b>
• MSW/Landfill Gas	20	80	5,000	90	1,500	900	600	160	<b>3,250</b>
• Biogas	20	80	60	70	1,180	690	430	120	<b>2,490</b>
• Pico/Micro Hydro	5	30	0.300	–	1,560	–	–	–	<b>1,560</b>
	15	30	1	–	1,970	570	140	–	<b>2,680</b>
	30	30	100	190	1,400	810	200	–	<b>2,600</b>
• Mini-hydro	30	45	5,000	200	990	1,010	170	–	<b>2,370</b>
• Large-hydro	40	50	100,000	200	560	1,180	200	–	<b>2,140</b>
• Pumped Storage	40	10	150,000	300	810	1,760	300	–	<b>3,170</b>

Note: “–” means no cost needed.

**Table 4.2: 2005 Conventional and Emerging Power Technology Capital Costs (US\$/kW)**

Technology	Life Years	Capacity Factor %	Rated Output kW	Engineering	Equipment & Materials	Civil	Erection	Process Contingency	Total	
• Diesel/Gasoline Generator	10	30	0.300	–	890	–	–	–	<b>890</b>	
	10	30	1	–	680	–	–	–	<b>680</b>	
	20	80	100	10	600	10	20	–	<b>640</b>	
Base Load	20	80	5,000	30	510	30	30	–	<b>600</b>	
Peak Load	20	10	5,000	30	510	30	30	–	<b>600</b>	
• Microturbines	20	80	150	10	830	10	20	90	<b>960</b>	
• Fuel Cell	20	80	200	–	3,100	–	20	520	<b>3,640</b>	
	20	80	5,000	–	3,095	5	10	520	<b>3,630</b>	
• Oil/Gas Combustion Turbines	25	10	150,000	30	370	45	45	–	<b>490</b>	
• Oil/Gas Combined Cycle	25	80	300,000	50	480	50	70	–	<b>650</b>	
• Coal Steam (with FGD & SCR)	SubCritical	30	80	300,000	100	870	110	110	–	<b>1,190</b>
	SubCritical	30	80	500,000	90	850	100	100	–	<b>1,140</b>
	SC	30	80	500,000	100	880	100	100	–	<b>1,180</b>
	USC	30	80	500,000	110	850	100	100	100	<b>1,260</b>
• Coal IGCC (without FGD & SCR)	30	80	300,000	150	1,010	150	100	200	<b>1,610</b>	
	30	80	500,000	140	940	140	100	180	<b>1,500</b>	
• Coal AFBC (without FGD & SCR)	30	80	300,000	110	730	120	120	100	<b>1,180</b>	
	30	80	500,000	110	680	120	110	100	<b>1,120</b>	
• Oil Steam	30	80	300,000	80	600	100	100	–	<b>880</b>	

Source: E.ON.

Note: “–” means no cost needed.

**Table 4.3: Power Generation Technology Capital Costs Now and in Future (2005, 2010, 2015)**

Generating-type	Capacity	2005			2010			2015		
		Min	Probable	Max	Min	Probable	Max	Min	Probable	Max
Solar-PV	50 W	6,430	<b>7,480</b>	8,540	5,120	<b>6,500</b>	7,610	4,160	<b>5,780</b>	6,950
	300 W	6,430	<b>7,480</b>	8,540	5,120	<b>6,500</b>	7,610	4,160	<b>5,780</b>	6,950
	25 kW	6,710	<b>7,510</b>	8,320	5,630	<b>6,590</b>	7,380	4,800	<b>5,860</b>	6,640
	5 MW	6,310	<b>7,060</b>	7,810	5,280	<b>6,190</b>	6,930	4,500	<b>5,500</b>	6,235
Wind	300 W	4,820	<b>5,370</b>	5,930	4,160	<b>4,850</b>	5,430	3,700	<b>4,450</b>	5,050

(continued...)

## RESULTS AND DISCUSSION

(...Table 4.3 continued)

Generating Type	Capacity	2005			2010			2015		
		Min	Probable	Max	Min	Probable	Max	Min	Probable	Max
	100 kW	2,460	<b>2,780</b>	3,100	2,090	<b>2,500</b>	2,850	1,830	<b>2,300</b>	2,670
	10 MW	1,270	<b>1,440</b>	1,610	1,040	<b>1,260</b>	1,440	870	<b>1,120</b>	1,300
	100 MW	1,090	<b>1,240</b>	1,390	890	<b>1,080</b>	1,230	750	<b>960</b>	1,110
PV-wind Hybrids	300 W	5,670	<b>6,440</b>	7,210	4,650	<b>5,630</b>	6,440	3,880	<b>5,000</b>	5,800
	100 kW	4,830	<b>5,420</b>	6,020	4,030	<b>4,750</b>	5,340	3,420	<b>4,220</b>	4,800
Solar Thermal (without thermal storage)	30 MW	2,290	<b>2,480</b>	2,680	1,990	<b>2,200</b>	2,380	1,770	<b>1,960</b>	2,120
Solar Thermal (with thermal storage)	30 MW	4,450	<b>4,850</b>	5,240	3,880	<b>4,300</b>	4,660	3,430	<b>3,820</b>	4,140
Geothermal	200 kW (binary)	6,480	<b>7,220</b>	7,950	5,760	<b>6,580</b>	7,360	5,450	<b>6,410</b>	7,300
	20 MW (binary)	3,690	<b>4,100</b>	4,500	3,400	<b>3,830</b>	4,240	3,270	<b>3,730</b>	4,170
	50 MW (flash)	2,260	<b>2,510</b>	2,750	2,090	<b>2,350</b>	2,600	2,010	<b>2,290</b>	2,560
Biomass Gasifier	100 kW	2,490	<b>2,880</b>	3,260	2,090	<b>2,560</b>	2,980	1,870	<b>2,430</b>	2,900
	20 MW	1,760	<b>2,030</b>	2,300	1,480	<b>1,810</b>	2,100	1,320	<b>1,710</b>	2,040
Biomass Steam	50 MW	1,500	<b>1,700</b>	1,910	1,310	<b>1,550</b>	1,770	1,240	<b>1,520</b>	1,780
MSW/Landfill Gas	5 MW	2,960	<b>3,250</b>	3,540	2,660	<b>2,980</b>	3,270	2,480	<b>2,830</b>	3,130
Biogas	60 kW	2,260	<b>2,490</b>	2,720	2,080	<b>2,330</b>	2,570	2,000	<b>2,280</b>	2,540
Pico/Micro Hydro	300W	1,320	<b>1,560</b>	1,800	1,190	<b>1,485</b>	1,770	1,110	<b>1,470</b>	1,810
	1 kW	2,360	<b>2,680</b>	3,000	2,190	<b>2,575</b>	2,950	2,090	<b>2,550</b>	2,990
	100 kW	2,350	<b>2,600</b>	2,860	2,180	<b>2,470</b>	2,750	2,110	<b>2,450</b>	2,780
Mini-hydro	5 MW	2,140	<b>2,370</b>	2,600	2,030	<b>2,280</b>	2,520	1,970	<b>2,250</b>	2,520
Large-hydro	100 MW	1,930	<b>2,140</b>	2,350	1,860	<b>2,080</b>	2,290	1,830	<b>2,060</b>	2,280
Pumped Storage Hydro	150 MW	2,860	<b>3,170</b>	3,480	2,760	<b>3,080</b>	3,400	2,710	<b>3,050</b>	3,380
Diesel/Gasoline Generator	300 W	750	<b>890</b>	1,030	650	<b>810</b>	970	600	<b>800</b>	980
	1kW	570	<b>680</b>	790	500	<b>625</b>	750	470	<b>620</b>	770
	100 kW	550	<b>640</b>	730	480	<b>595</b>	700	460	<b>590</b>	720
	5 MW (baseload)	520	<b>600</b>	680	460	<b>555</b>	650	440	<b>550</b>	660
	5 MW (peak load)	520	<b>600</b>	680	460	<b>555</b>	650	440	<b>550</b>	660
Micro Turbines	150 kW	830	<b>960</b>	1,090	620	<b>780</b>	910	500	<b>680</b>	810
Fuel Cells	200 kW	3,150	<b>3,640</b>	4,120	2,190	<b>2,820</b>	3,260	1,470	<b>2,100</b>	2,450
	5 MW	3,150	<b>3,630</b>	4,110	2,180	<b>2,820</b>	3,260	1,470	<b>2,100</b>	2,450

(continued...)

(...Table 4.3 continued)

Generating Type	Capacity	2005			2010			2015		
		Min	<b>Probable</b>	Max	Min	<b>Probable</b>	Max	Min	<b>Probable</b>	Max
Oil/Gas Combined Turbines	150 MW (1,100C class)	430	<b>490</b>	550	360	<b>430</b>	490	340	<b>420</b>	490
Oil/Gas Combined Cycle	300 MW (1,300C class)	570	<b>650</b>	720	490	<b>580</b>	660	450	<b>560</b>	650
Coal Steam with FGD and SCR (Subcritical)	300 MW	1,080	<b>1,190</b>	1,310	960	<b>1,080</b>	1,220	910	<b>1,060</b>	1,200
Coal Steam with FGD and SCR (Subcritical)	500 MW	1,030	<b>1,140</b>	1,250	910	<b>1,030</b>	1,150	870	<b>1,010</b>	1,140
Coal Steam with FGD and SCR (SC)	500 MW	1,070	<b>1,180</b>	1,290	950	<b>1,070</b>	1,200	900	<b>1,050</b>	1,190
Coal Steam with FGD and SCR (USC)	500 MW	1,150	<b>1,260</b>	1,370	1,020	<b>1,140</b>	1,250	960	<b>1,100</b>	1,230
Coal AFB without FGD and SCR	300 MW	1,060	<b>1,180</b>	1,300	940	<b>1,070</b>	1,210	880	<b>1,040</b>	1,180
	500 MW	1,010	<b>1,120</b>	1,230	900	<b>1,020</b>	1,140	840	<b>990</b>	1,120
Coal IGCC without FGD and SCR	300 MW	1,450	<b>1,610</b>	1,770	1,200	<b>1,390</b>	1,550	1,070	<b>1,280</b>	1,440
	500 MW	1,350	<b>1,500</b>	1,650	1,130	<b>1,300</b>	1,450	1,000	<b>1,190</b>	1,340
Oil Steam	300 MW	780	<b>880</b>	980	700	<b>810</b>	920	670	<b>800</b>	920

## Results: Levelized Power Generating Costs

A useful expression for comparing different power supply costs is the levelized power generating costs expressed on a per-kWh basis. Table 4.4 and Table 4.5 provide levelized generation costs for 2005 for renewable power generation technologies and conventional and emerging power technologies, respectively. The components of generation operating costs (levelized capital costs, O&M costs and fuel costs) are provided for all 42 power generation technology configurations assessed. Table 4.6 provides the average and estimated uncertainty band results for generation costs in 2005, 2010 and 2015.

In large grid-connected configurations, most of the conventional, renewable and emerging power generation technologies are comparably priced at around US\$4-6/kWh. Geothermal, coal-fired steam electric and coal AFBC are the most competitive at present, with wind and coal IGCC expected to join this mix by 2015. Site-specific considerations such as load profile, demand growth and especially the cost differential between oil, natural gas and coal prices, determine which specific technology is the least expensive and most attractive. Both oil-fired steam electric and gas combined cycle are expected to become more costly instead of less over the next 10 years.

As regards small grid-connected power generation configurations (less than 50 MW), there is a much greater generating cost spread among power technologies, with most renewable technologies being more economical than the conventional diesel generator alternative.

**Table 4.4: 2005 Renewable Power Technology Generating Costs (US¢/kWh)**

Technology	Rated Output kW	Levelized Capital Cost	Fixed O&M Costs	Variable O&M Costs	Fuel Costs	Average Levelized Cost
• Solar-PV	0.050	45.59	3.00	13.00	–	61.59
	0.300	45.59	2.50	8.00	–	56.09
	25	42.93	1.50	7.00	–	51.43
	5,000	40.36	0.97	0.24	–	41.57
• Wind	0.300	26.18	3.49	4.90	–	34.57
	100	13.55	2.08	4.08	–	19.71
	10,000	5.85	0.66	0.26	–	6.71
	100,000	5.08	0.53	0.22	–	5.79
• PV-wind-hybrid	0.300	31.40	3.48	6.90	–	41.78
	100	22.02	2.07	6.40	–	30.49
• Solar-thermal	With Storage 30,000	10.68	1.82	0.45	–	12.95
	Without Storage 30,000	13.65	3.01	0.75	–	17.41
• Geothermal	Binary 200	12.57	2.00	1.00	–	15.57
	Binary 20,000	5.02	1.30	0.40	–	6.72
	Flash 50,000	3.07	0.90	0.30	–	4.27
• Biomass Gasifier	100	4.39	0.34	1.57	2.66	8.96
	20,000	3.09	0.25	1.18	2.50	7.02
• Biomass Steam	50,000	2.59	0.45	0.41	2.50	5.95
• MSW/Landfill Gas	5,000	4.95	0.11	0.43	1.00	6.49
• Biogas	60	3.79	0.34	1.54	1.10	6.77
• Pico/Micro-hydro	0.300	14.24	0.00	0.90	–	15.14
	1	12.19	0.00	0.54	–	12.73
	100	9.54	1.05	0.42	–	11.01
• Mini-hydro	5,000	5.86	0.74	0.35	–	6.95
• Large-hydro	100,000	4.56	0.50	0.32	–	5.38
• Pumped Storage	150,000	34.08	0.32	0.33	–	34.73

Note: “–” means no cost needed.

**Table 4.5: 2005 Conventional/Emerging Power Technology Generating Costs (US¢/kWh)**

Technology	Rated Output kW	Levelized Capital Cost	Fixed O&M Costs	Variable O&M Costs	Fuel Costs	Total	
• Diesel/Gasoline Generator	0.300	5.01	–	5.00	54.62	<b>64.63</b>	
	1	3.83	–	3.00	44.38	<b>51.21</b>	
	100	0.98	2.00	3.00	14.04	<b>20.02</b>	
	Baseload	5,000	0.91	1.00	2.50	4.84	<b>9.25</b>
	Peak Load	5,000	7.31	3.00	2.50	4.84	<b>17.65</b>
• Microturbines	150	1.46	1.00	2.50	26.86	<b>31.82</b>	
• Fuel Cell	200	5.60	0.10	4.50	16.28	<b>26.48</b>	
	5,000	5.59	0.10	4.50	4.18	<b>14.36</b>	
• Combustion Turbines	Natural Gas Oil	150,000	5.66	0.30	1.00	6.12	<b>13.08</b>
			5.66	0.30	1.00	15.81	<b>22.77</b>
• Combined Cycle	Natural Gas Oil	300,000	0.95	0.10	0.40	4.12	<b>5.57</b>
			0.95	0.10	0.40	10.65	<b>12.10</b>
• Coal Steam (with FGD & SCR)	SubCritical	300,000	1.76	0.38	0.36	1.97	<b>4.47</b>
	SubCritical	500,000	1.67	0.38	0.36	1.92	<b>4.33</b>
	SC	500,000	1.73	0.38	0.36	1.83	<b>4.29</b>
	USC	500,000	1.84	0.38	0.36	1.70	<b>4.29</b>
• Coal IGCC (without FGD & SCR)		300,000	2.49	0.90	0.21	1.79	<b>5.39</b>
		500,000	2.29	0.90	0.21	1.73	<b>5.14</b>
• Coal AFBC (without FGD & SCR)		300,000	1.75	0.50	0.34	1.52	<b>4.11</b>
		500,000	1.64	0.50	0.34	1.49	<b>3.97</b>
• Oil Steam		300,000	1.27	0.35	0.30	5.32	<b>7.24</b>

Note: “–” means no cost needed.

Geothermal and wind both have excellent prospects, local resource availability allowing, with costs estimated at US¢4-6/kWh. Several biomass technologies (biomass gasifier, biomass steam and waste-to-power via Anaerobic Digestion) all are estimated to cost around US¢5-7/kWh both now and in future.

Mini-grid applications are village- and district-level networks with loads between 5 kW and 500 kW not connected to a national grid. The assessment indicates that numerous RE technologies (biomass, biogas, geothermal, wind and micro-hydro) costing

US¢6-15/kWh are the potential least-cost generation option for mini-grids, assuming a sufficient RE resource is available. Two biomass technologies – biogas digesters and biomass gasifiers – seem particularly promising, due to their high capacity factors and availability in size ranges matched to mini-grid loads. Geothermal also appears economical, recognizing that it is restricted to a relatively few developing economies. Since so many RE sources are viable in this size range, mini-grid planners should thoroughly review their options to make the best selection.

The only electrification technology choice for small, isolated loads is expensive diesel generation and several renewable power options, including pico-hydro, geothermal, small wind and solar PV. These renewable technologies are the least-cost option on a levelized generating cost basis for off-grid electrification, assuming resource availability. However, these off-grid configurations are very expensive (US¢30-50/kWh), with pico-hydro the notable exception at only US¢12/kWh. However, they are economical when compared with the US¢45-60/kWh for a small, stand-alone gasoline or diesel engine generator.

### **Discussion: Power Delivery Costs**

The costs of transmitting and distributing electricity production need to be included in the overall economic assessment of different power generation configurations. As described in Section 3, the capital costs of transmission and delivery are driven by the amount of power transmitted and the distance over which delivery takes place. For large grid-connected power plants, comparably located with respect to the load being served the associated transmission and distribution costs cancel out and a comparison can be made based on generation costs alone. However, for some smaller loads with low capacity factors, especially in a mini-grid configuration, the power delivery costs on a levelized basis can vary considerably when spread across the amount of electricity delivered. These costs need to be taken into account in a way that does not unduly tilt the economic assessment according to capacity factor. Because the economic assessment of power delivery requirements needs more development, we do not include the capital cost or levelized cost of power delivery in our comparisons of power generation technology alternatives.

### **Discussion: Sensitivity of Projected Generation Costs to Technology Change and Fuel Costs**

As described in the Executive Summary, many renewable power generation technologies are expected to have improved performance and lower capital costs in the near future. Some conventional power generation technologies, especially coal- and oil-fired steam electric, also have prospects for improved performance and lower costs through use of advanced materials allowing higher temperature operation. Additionally, several emerging technologies, including microturbines and fuel cells as well as coal-fired IGCC and AFBC,

are expected to be very competitive within a few years. We have done our best to anticipate the performance improvements and capital cost reductions of these technologies based on industry literature and forecasts.

An additional key factor in projecting future costs is the cost of fuel. Any fossil fuel using power generation technology and especially oil- and gas-fired technologies are subject to secular fuel price increases, fuel price fluctuations and growing risk of availability. Gas and oil price forecasts have uniformly taken on a broader error band just in the past year.

These factors – performance improvements outlook, cost reduction trajectories and uncertainties in cost input assumptions – were captured in projections of capital and production costs for each power generation technology in 2010 and 2015. An uncertainty analysis allowed future capital and generation cost projections to include an “uncertainty band” around the average cost estimate for each technology and configuration.

An argument can be made that conservative power system planners would be better off choosing power generation technologies that have a narrower sensitivity range in future capital and generating costs forecasts. Generation technologies that are not dependent on fossil fuels and are fairly well developed at present will tend to have the narrowest sensitivities in forecast capital or generating cost. This category includes several of the RETs, notably the biomass, hydroelectric and geothermal technologies across size ranges. Such insensitivity to technology or fuel price variability could be a competitive advantage for these technologies.

## **Conclusion**

RETs fare surprisingly well in several electrification configurations. In addition to proving more economical in the very expensive off-grid category, they are also more economical in mini-grid applications and even when compared with small grid-connected generation (less than 50 MW). Since power system planners generally operate on an incremental basis, with new capacity additions (generation, transmission or distribution) timed and sized to accommodate the location and pace of load growth, the findings here suggest that scale and insensitivity to fuel and technology change factors could affect the economics of choosing generation configurations in future. When the national or regional grid is developed and includes sufficient transmission capacity, and incremental load growth is fast, large, central-station gas combined cycle and coal fired power plants would clearly be the least-cost alternatives. However, if the size of the grid is limited, or the incremental load growth is small, it may make economic sense to add several smaller renewable or diesel power stations rather than add one very large conventional power station. Taking advantage of local resources such as indigenous coal, gas, biomass or geothermal or wind or hydro and constructing smaller power stations may provide energy security and avoid some of the uncertainty associated with international fuel prices.



**Table 4.6: Levelized Generating Cost with Uncertainty Analysis**

Generating-types	Capacity			2005			2010			2015		
	Mini	Probable	Max	Mini	Probable	Max	Mini	Probable	Max	Mini	Probable	Max
Solar-PV	50 W	51.8	<b>61.6</b>	75.1	44.9	<b>55.6</b>	67.7	39.4	<b>51.2</b>	62.8		
	300 W	46.4	<b>56.1</b>	69.5	39.6	<b>50.1</b>	62.1	34.2	<b>45.7</b>	57.0		
	25 kW	43.1	<b>51.4</b>	63.0	37.7	<b>46.2</b>	56.6	33.6	<b>42.0</b>	51.3		
Wind	5 MW	33.7	<b>41.6</b>	52.6	28.9	<b>36.6</b>	46.3	25.0	<b>32.7</b>	41.4		
	300 W	30.1	<b>34.6</b>	40.4	27.3	<b>32.0</b>	37.3	25.2	<b>30.1</b>	35.1		
	100 kW	17.2	<b>19.7</b>	22.9	15.6	<b>18.3</b>	21.3	14.4	<b>17.4</b>	20.2		
PV-wind-hybrids	10 MW	5.8	<b>6.8</b>	8.0	5.0	<b>6.0</b>	7.1	4.3	<b>5.5</b>	6.5		
	100 MW	5.0	<b>5.8</b>	6.8	4.2	<b>5.1</b>	6.1	3.7	<b>4.7</b>	5.5		
	300 W	36.1	<b>41.8</b>	48.9	31.6	<b>37.8</b>	44.5	28.1	<b>34.8</b>	40.9		
Solar-thermal (without thermal storage)	100 kW	26.8	<b>30.5</b>	34.8	23.8	<b>27.8</b>	31.7	21.4	<b>25.6</b>	29.1		
	30 MW	14.9	<b>17.4</b>	21.0	13.5	<b>15.9</b>	19.0	12.4	<b>14.5</b>	17.3		
	30 MW	11.7	<b>12.9</b>	14.3	10.5	<b>11.7</b>	12.9	9.6	<b>10.7</b>	11.7		
Geothermal	200 kW (binary)	14.2	<b>15.6</b>	16.9	13.0	<b>14.5</b>	15.9	12.5	<b>14.2</b>	15.7		
	20 MW (binary)	6.2	<b>6.7</b>	7.3	5.8	<b>6.4</b>	6.9	5.7	<b>6.3</b>	6.8		
	50 MW (flash)	3.9	<b>4.3</b>	4.6	3.7	<b>4.1</b>	4.4	3.6	<b>4.0</b>	4.4		
Biomass Gasifier	100 kW	8.2	<b>9.0</b>	9.7	7.6	<b>8.5</b>	9.4	7.3	<b>8.3</b>	9.5		
	20 MW	6.4	<b>7.0</b>	7.6	6.0	<b>6.7</b>	7.5	5.8	<b>6.5</b>	7.5		
Biomass Steam	50 MW	5.4	<b>6.0</b>	6.5	5.2	<b>5.7</b>	6.4	5.1	<b>5.7</b>	6.6		
MSW/Landfill Gas	5 MW	6.0	<b>6.5</b>	7.0	5.6	<b>6.1</b>	6.6	5.3	<b>5.9</b>	6.4		
	60 kW	6.3	<b>6.8</b>	7.2	6.0	<b>6.5</b>	7.1	5.9	<b>6.5</b>	7.1		
Pico/Micro Hydro	300 W	12.4	<b>15.1</b>	18.4	11.4	<b>14.5</b>	18.0	10.8	<b>14.3</b>	18.2		
	1 kW	10.7	<b>12.7</b>	15.2	10.1	<b>12.3</b>	14.8	9.7	<b>12.1</b>	14.9		

(continued...)

(...Table 4.6 continued)

Generating-types	Capacity	2005	2010	2015					
Mini Hydro	100 kW	9.6	12.8	9.1	10.5	12.3	8.9	10.5	12.3
Large Hydro	5 MW	5.9	8.3	5.7	6.7	8.1	5.6	6.6	8.0
Pumped Storage Hydro	100 MW	4.6	6.3	4.5	5.2	6.2	4.5	5.2	6.2
Diesel/Gasoline Generator	150 MW	31.4	38.1	30.3	33.8	37.2	29.9	33.4	36.9
	300 W	59.0	72.5	52.4	59.7	71.8	52.5	60.2	75.0
	1 kW	46.7	57.6	41.4	47.3	57.1	41.5	47.7	59.7
	100 kW	18.1	23.1	16.6	19.0	23.3	16.7	19.2	24.3
	5 MW (base load)	8.3	10.8	7.6	8.7	10.8	7.6	8.8	11.3
	5 MW (peak load)	16.2	19.6	15.0	16.7	19.1	14.9	16.7	19.6
Microturbines	150 kW	30.4	33.9	28.8	30.7	33.5	28.5	30.7	34.2
Fuel Cells	200 kW	25.2	28.2	22.8	24.7	26.6	21.5	23.7	25.8
	5 MW	13.2	15.8	11.0	12.7	14.4	9.6	11.7	13.4
Oil/Gas Combustion Turbines	150 MW (1,100C class)	11.9	14.7	10.4	11.8	14.0	10.2	11.8	14.5
Oil/Gas Combined Cycle	300 MW (1,300C class)	4.94	6.55	4.26	5.10	6.47	4.21	5.14	6.85
Coal Steam with FGD & SCR (SubCritical)	300 MW	4.18	4.95	3.91	4.20	4.76	3.86	4.20	4.84
Coal Steam with FGD & SCR (SubCritical)	500 MW	4.05	4.79	3.77	4.07	4.62	3.74	4.06	4.69
Coal Steam with FGD & SCR (SubCritical)	500 MW	4.02	4.74	3.74	4.04	4.56	3.72	4.03	4.63
Coal Steam with FGD & SCR (UltraSuperCritical)	500 MW	4.02	4.71	3.74	4.02	4.51	3.69	3.99	4.55
Coal AFB without FGD & SCR	300 MW	3.88	4.56	3.72	3.98	4.55	3.67	3.96	4.55
	500 MW	3.75	4.40	3.61	3.86	4.42	3.58	3.83	4.71
Coal IGCC without FGD & SCR	300 MW	5.05	5.90	4.58	4.95	5.52	4.40	4.81	5.43
	500 MW	4.81	5.62	4.38	4.74	5.28	4.21	4.60	5.19
Oil Steam	300 MW	6.21	9.00	5.50	6.70	9.08	5.49	6.78	9.63

## 5. References

ASTE: "Statistical Analysis of Wind Farm Costs and Policy Regimes," Working Paper.

Barnes, Douglas, 2006: *Meeting the Challenge of Rural Electrification in Developing Nations: The Experience of Successful Programs*. ESMAP Discussion Paper, The World Bank, Washington, DC.

Bechtel Power: "Incremental Cost of CO<sub>2</sub> Reduction in Power Plants," presented at the ASME Turbo Expo, 2002.

Booras, G. (EPRI) "Pulverized Coal and IGCC Plant Cost and Performance Estimates," Gasification Technologies 2004, Washington, DC, October 3-6, 2004.

DOE/EPRI (1997): "Renewable Energy Technology Characterizations," TR-109496.

EPRI: "Gasification Process Selection – Trade offs and Ironies," presented at the Gasification Technologies Conference 2004.

Institute of Applied Energy: "Gas Microturbines."

International Energy Agency (IEA). 2002: *World Energy Outlook*. Paris: International Energy Agency.

International Energy Agency (IEA). 2004: *World Energy Outlook*. Paris: International Energy Agency.

Palkes, M., Waryasz, R.: "Economics and Feasibility of Rankine Cycle Improvements for Coal Fired Power Plants." Final DOE-NETL Report under Cooperative Agreement No. DE-FCP-01NT41222 Prepared by Alstom Power Inc., February 2004.

Saghir, Jamal, 2005: *Energy and Poverty: Myths, Links, and Policy Issues*. Energy Working Note No. 4, May 2005. Energy and Mining Sector Board Paper, The World Bank, Washington, DC.

The World Bank, 2001: ESMAP: "Technology Assessment of Clean Coal Technologies for China: Electric Power Production," Volume I, May 2001.

The World Bank, 2002: *The World Bank Group's Energy Program – Poverty Reduction, Sustainability, and Selectivity*. Energy and Mining Sector Board Paper, The World Bank, Washington, DC.

The World Bank, 2003: Infrastructure Action Plan.

The World Bank, 2004: *Renewing our Energy Business: The World Bank Group Energy Program Implementation Progress Report 2001-03*. The World Bank, Washington, DC.

The World Bank, 2006: *The Role of the World Bank for Energy Access: A Portfolio Review for Fiscal Years 2003-05*, September 2006. Douglas F. Barnes, Grayson Heffner and Xiaoyu Shi.

# List of Technical Reports

Region/Country	Activity/Report Title	Date	Number
<b>SUB-SAHARAN AFRICA (AFR)</b>			
Regional	Power Trade in Nile Basin Initiative Phase II (CD Only): Part I: Minutes of the High-level Power Experts Meeting; and Part II: Minutes of the First Meeting of the Nile Basin Ministers Responsible for Electricity	04/05	067/05
	Introducing Low-cost Methods in Electricity Distribution Networks	10/06	104/06
	Second Steering Committee: The Road Ahead. Clean Air Initiative In Sub-Saharan African Cities. Paris, March 13-14, 2003	12/03	045/03
	Lead Elimination from Gasoline in Sub-Saharan Africa. Sub-regional Conference of the West-Africa group. Dakar, Senegal March 26-27, 2002 (Deuxième comité directeur : La route à suivre - L'initiative sur l'assainissement de l'air. Paris, le 13-14 mars 2003)	12/03	046/03
	1998-2002 Progress Report. The World Bank Clean Air Initiative in Sub-Saharan African Cities. Working Paper #10 (Clean Air Initiative/ESMAP)	02/02	048/04
	Landfill Gas Capture Opportunity in Sub Saharan Africa	06/05	074/05
	The Evolution of Enterprise Reform in Africa: From State-owned Enterprises to Private Participation in Infrastructure-and Back? Market Development	11/05	084/05
		12/01	017/01
Cameroon	Decentralized Rural Electrification Project in Cameroon	01/05	087/05
Chad	Revenue Management Seminar. Oslo, June 25-26, 2003. (CD Only)	06/05	075/05
Côte d'Ivoire	Workshop on Rural Energy and Sustainable Development, January 30-31, 2002. ( <i>Atelier sur l'Energie en régions rurales et le Développement durable 30-31, janvier 2002</i> )	04/05	068/05
East Africa	Sub-Regional Conference on the Phase-out Leaded Gasoline in East Africa. June 5-7, 2002	11/03	044/03
Ethiopia	Phase-Out of Leaded Gasoline in Oil Importing Countries of Sub-Saharan Africa: The Case of Ethiopia - Action Plan	12/03	038/03
	Sub-Saharan Petroleum Products Transportation Corridor: Analysis and Case Studies	03/03	033/03
	Phase-Out of Leaded Gasoline in Sub-Saharan Africa	04/02	028/02
	Energy and Poverty: How can Modern Energy Services Contribute to Poverty Reduction	03/03	032/03
Ghana	Poverty and Social Impact Analysis of Electricity Tariffs	12/05	088/05
	Women Enterprise Study: Developing a Model for Mainstreaming Gender into Modern Energy Service Delivery	03/06	096/06
	Sector Reform and the Poor: Energy Use and Supply in Ghana	03/06	097/06
Kenya	Field Performance Evaluation of Amorphous Silicon (a-Si) Photovoltaic Systems in Kenya: Methods and Measurement in Support of a Sustainable Commercial Solar Energy Industry	08/00	005/00

Region/Country	Activity/Report Title	Date	Number
	The Kenya Portable Battery Pack Experience: Test Marketing an Alternative for Low-Income Rural Household Electrification	12/01	05/01
Malawi	Rural Energy and Institutional Development	04/05	069/05
Mali	Phase-Out of Leaded Gasoline in Oil Importing Countries of Sub-Saharan Africa: The Case of Mali - Action Plan ( <i>Elimination progressive de l'essence au plomb dans les pays importateurs de pétrole en Afrique subsaharienne</i> <i>Le cas du Mali — Mali Plan d'action</i> )	12/03	041/03
Mauritania	Phase-Out of Leaded Gasoline in Oil Importing Countries of Sub-Saharan Africa: The Case of Mauritania - Action Plan ( <i>Elimination progressive de l'essence au plomb dans les pays importateurs de pétrole en Afrique subsaharienne</i> <i>Le cas de la Mauritanie – Plan d'action.</i> )	12/03	040/03
Nigeria	Phase-Out of Leaded Gasoline in Nigeria	11/02	029/02
	Nigerian LP Gas Sector Improvement Study	03/04	056/04
	Taxation and State Participation in Nigeria's Oil and Gas Sector	08/04	057/04
Senegal	Regional Conference on the Phase-Out of Leaded Gasoline in Sub-Saharan Africa ( <i>Elimination du plomb dans l'essence en Afrique subsaharienne Conference sous regionales du Groupe Afrique de l'Ouest</i> <i>Dakar, Sénégal. March 26-27, 2002.</i> )	03/02	022/02
	Alleviating Fuel Adulteration Practices in the Downstream Oil Sector in Senegal	12/03	046/03
		09/05	079/05
South Africa	South Africa Workshop: People's Power Workshop.	12/04	064/04
Swaziland	Solar Electrification Program 2001 2010: Phase 1: 2001 2002 (Solar Energy in the Pilot Area)	12/01	019/01
Tanzania	Mini Hydropower Development Case Studies on the Malagarasi, Muhuwei, and Kikuletwa Rivers Volumes I, II, and III	04/02	024/02
	Phase-Out of Leaded Gasoline in Oil Importing Countries of Sub-Saharan Africa: The Case of Tanzania - Action Plan	12/03	039/03
Uganda	Report on the Uganda Power Sector Reform and Regulation Strategy Workshop	08/00	004/00
<b>EAST ASIA AND PACIFIC (EAP)</b>			
Cambodia	Efficiency Improvement for Commercialization of the Power Sector	10/02	031/02
	TA For Capacity Building of the Electricity Authority	09/05	076/05
China	Assessing Markets for Renewable Energy in Rural Areas of Northwestern China	08/00	003/00
	Technology Assessment of Clean Coal Technologies for China Volume I-Electric Power Production	05/01	011/01
	Technology Assessment of Clean Coal Technologies for China Volume II-Environmental and Energy Efficiency Improvements for Non-power Uses of Coal	05/01	011/01
	Technology Assessment of Clean Coal Technologies for China Volume III-Environmental Compliance in the Energy Sector: Methodological Approach and Least-Cost Strategies	12/01	011/01
	Policy Advice on Implementation of Clean Coal Technology	09/06	104/06
	Scoping Study for Voluntary Green Electricity Schemes in Beijing and Shanghai	09/06	105/06
Papua New Guinea	Energy Sector and Rural Electrification Background Note	03/06	102/06
Philippines	Rural Electrification Regulation Framework. (CD Only)	10/05	080/05
Thailand	DSM in Thailand: A Case Study	10/00	008/00
	Development of a Regional Power Market in the Greater Mekong Sub-Region (GMS)	12/01	015/01
	Greater Mekong Sub-region Options for the Structure of the GMS Power Trade Market A First Overview of Issues and Possible Options	12/06	108/06
Vietnam	Options for Renewable Energy in Vietnam	07/00	001/00
	Renewable Energy Action Plan	03/02	021/02

Region/Country	Activity/Report Title	Date	Number
	Vietnam's Petroleum Sector: Technical Assistance for the Revision of the Existing Legal and Regulatory Framework	03/04	053/04
	Vietnam Policy Dialogue Seminar and New Mining Code	03/06	098/06
<b>SOUTH ASIA (SAS)</b>			
Bangladesh	Workshop on Bangladesh Power Sector Reform	12/01	018/01
	Integrating Gender in Energy Provision: The Case of Bangladesh	04/04	054/04
	Opportunities for Women in Renewable Energy Technology Use In Bangladesh, Phase I	04/04	055/04
<b>EUROPE AND CENTRAL ASIA (ECA)</b>			
Azerbaijan	Natural Gas Sector Re-structuring and Regulatory Reform	03/06	099/06
Macedonia	Elements of Energy and Environment Strategy in Macedonia	03/06	100/06
Poland	Poland (URE): Assistance for the Implementation of the New Tariff Regulatory System: Volume I, Economic Report, Volume II, Legal Report	03/06	101/06
Russia	Russia Pipeline Oil Spill Study	03/03	034/03
Uzbekistan	Energy Efficiency in Urban Water Utilities in Central Asia	10/05	082/05
<b>MIDDLE EASTERN AND NORTH AFRICA REGION (MENA)</b>			
Morocco	Amélioration de l'Efficacité Energie: Environnement de la Zone Industrielle de Sidi Bernoussi, Casablanca	12/05	085/05
Regional	Roundtable on Opportunities and Challenges in the Water, Sanitation And Power Sectors in the Middle East and North Africa Region. Summary Proceedings, May 26-28, 2003. Beit Mary, Lebanon. (CD)	02/04	049/04
Turkey	Gas Sector Strategy	05/07	114/07
<b>LATIN AMERICA AND THE CARIBBEAN REGION (LCR)</b>			
Regional	Regional Electricity Markets Interconnections - Phase I Identification of Issues for the Development of Regional Power Markets in South America	12/01	016/01
	Regional Electricity Markets Interconnections - Phase II Proposals to Facilitate Increased Energy Exchanges in South America	04/02	016/01
	Population, Energy and Environment Program (PEA) Comparative Analysis on the Distribution of Oil Rents (English and Spanish)	02/02	020/02
	Estudio Comparativo sobre la Distribución de la Renta Petrolera Estudio de Casos: Bolivia, Colombia, Ecuador y Perú	03/02	023/02
	Latin American and Caribbean Refinery Sector Development Report - Volumes I and II	08/02	026/02
	The Population, Energy and Environmental Program (EAP) (English and Spanish)	08/02	027/02
	Bank Experience in Non-energy Projects with Rural Electrification Components: A Review of Integration Issues in LCR	02/04	052/04
	Supporting Gender and Sustainable Energy Initiatives in Central America	12/04	061/04
	Energy from Landfill Gas for the LCR Region: Best Practice and Social Issues (CD Only)	01/05	065/05
	Study on Investment and Private Sector Participation in Power Distribution in Latin America and the Caribbean Region	12/05	089/05
	Strengthening Energy Security in Uruguay	05/07	116/07
Bolivia	Country Program Phase II: Rural Energy and Energy Efficiency Report on Operational Activities	05/05	072/05
	Bolivia: National Biomass Program. Report on Operational Activities	05/07	115/07

Region/Country	Activity/Report Title	Date	Number
Brazil	Background Study for a National Rural Electrification Strategy: Aiming for Universal Access	03/05	066/05
	How do Peri-Urban Poor Meet their Energy Needs: A Case Study of Caju Shantytown, Rio de Janeiro	02/06	094/06
	Integration Strategy for the Southern Cone Gas Networks	05/07	113/07
Chile	Desafíos de la Electrificación Rural	10/05	082/05
Colombia	Desarrollo Económico Reciente en Infraestructura: Balanceando las necesidades sociales y productivas de la infraestructura	03/07	325/05
Ecuador	Programa de Entrenamiento a Representantes de Nacionalidades Amazónicas en Temas Hidrocarbúricos	08/02	025/02
	Stimulating the Picohydropower Market for Low-Income Households in Ecuador	12/05	090/05
Guatemala	Evaluation of Improved Stove Programs: Final Report of Project Case Studies	12/04	060/04
Haiti	Strategy to Alleviate the Pressure of Fuel Demand on National Woodfuel Resources (English) <i>(Stratégie pour l'allègement de la Pression sur les Ressources Ligneuses Nationales par la Demande en Combustibles)</i>	04/07	112/07
Honduras	Remote Energy Systems and Rural Connectivity: Technical Assistance to the Aldeas Solares Program of Honduras	12/05	092/05
Mexico	Energy Policies and the Mexican Economy	01/04	047/04
	Technical Assistance for Long-Term Program for Renewable Energy Development	02/06	093/06
Nicaragua	Aid-Memoir from the Rural Electrification Workshop (Spanish only)	03/03	030/04
	Sustainable Charcoal Production in the Chinandega Region	04/05	071/05
Perú	Extending the Use of Natural Gas to Inland Perú (Spanish/English)	04/06	103/06
	Solar-diesel Hybrid Options for the Peruvian Amazon Lessons Learned from Padre Cocha	04/07	111/07
<b>GLOBAL</b>			
	Impact of Power Sector Reform on the Poor: A Review of Issues and the Literature	07/00	002/00
	Best Practices for Sustainable Development of Micro Hydro Power in Developing Countries	08/00	006/00
	Mini-Grid Design Manual	09/00	007/00
	Photovoltaic Applications in Rural Areas of the Developing World	11/00	009/00
	Subsidies and Sustainable Rural Energy Services: Can we Create Incentives Without Distorting Markets?	12/00	010/00
	Sustainable Woodfuel Supplies from the Dry Tropical Woodlands	06/01	013/01
	Key Factors for Private Sector Investment in Power Distribution	08/01	014/01
	Cross-Border Oil and Gas Pipelines: Problems and Prospects	06/03	035/03
	Monitoring and Evaluation in Rural Electrification Projects: A Demand-Oriented Approach	07/03	037/03
	Household Energy Use in Developing Countries: A Multicountry Study	10/03	042/03
	Knowledge Exchange: Online Consultation and Project Profile from South Asia Practitioners Workshop. Colombo, Sri Lanka, June 2-4, 2003	12/03	043/03
	Energy & Environmental Health: A Literature Review and Recommendations	03/04	050/04
	Petroleum Revenue Management Workshop	03/04	051/04
	Operating Utility DSM Programs in a Restructuring Electricity Sector	12/05	058/04
	Evaluation of ESMAP Regional Power Trade Portfolio (TAG Report)	12/04	059/04
	Gender in Sustainable Energy Regional Workshop Series: Mesoamerican Network on Gender in Sustainable Energy (GENES) Winrock and ESMAP	12/04	062/04
	Women in Mining Voices for a Change Conference (CD Only)	12/04	063/04



<b>Region/Country</b>	<b>Activity/Report Title</b>	<b>Date</b>	<b>Number</b>
	Renewable Energy Potential in Selected Countries: Volume I: North Africa, Central Europe, and the Former Soviet Union, Volume II: Latin America	04/05	070/05
	Renewable Energy Toolkit Needs Assessment	08/05	077/05
	Portable Solar Photovoltaic Lanterns: Performance and Certification Specification and Type Approval	08/05	078/05
	Crude Oil Prices Differentials and Differences in Oil Qualities: A Statistical Analysis	10/05	081/05
	Operating Utility DSM Programs in a Restructuring Electricity Sector	12/05	086/05
	Sector Reform and the Poor: Energy Use and Supply in Four Countries: Botswana, Ghana, Honduras and Senegal	03/06	095/06
	Meeting the Energy Needs of the Urban Poor: Lessons from Electrification Practitioners	06/07	118/07
	Technical and Economic Assessment of Off-Grid, Mini-Grid and Grid Electrification Technologies	12/07	121/07







THE WORLD BANK



Energy Sector Management Assistance Program  
1818 H Street, NW  
Washington, DC 20433 USA  
Tel: 1.202.458.2321  
Fax: 1.202.522.3018  
Internet: [www.esmap.org](http://www.esmap.org)  
E-mail: [esmap@worldbank.org](mailto:esmap@worldbank.org)